

Hot closed die forging – State-of-Art and future development

B. Tomov*

Department of Materials Science and Technology, University of Rouse, 8 Studentska St., Rouse 7017, Bulgaria

* Corresponding author: E-mail address: btomov@ru.acad.bg

Received 20.03.2007; published in revised form 01.09.2007

Manufacturing and processing

ABSTRACT

Purpose: This paper presents an overview of the hot close-die- forging (HCDF) and aims at drawing up some new ideas and conclusions about future development of the HCDF.

Design/methodology/approach: Exploring the literature survey and the author's experience, the state-of-art of the HCDF is defined. The reason to do this are signs of instability in development of HCDF – a production method, well known due to its advantages, concerning both dimension accuracy and favorable mechanical properties in effect of micro structure changes.

Findings: This study shows advantages, possibilities and feature development of the HCDF. Challenges and possible response to them have been discussed.

Research limitations/implications: Analyzing the experience gained until now, the possible new research fields have been shown: forging of new materials, new understand ness of near-nett forging, combining operations, physical and numerical simulations.

Practical implications: HCDF is a production method, well known due to its advantages, concerning both dimension accuracy and favorable mechanical properties in effect of microstructure changes.

Keywords: Closed die forging; Process planning; Near-nett forging

1. Introduction

The forging and its variety hot closed-die-forging (CDF), (or hot impression forging), beyond any doubt, is the oldest metal processing technology. It started when the prehistoric people learned to smith virgin gold peaces and later to heat sponge iron and to beat it with a stone in order to form useful implements. For a long time forging has strongly depended upon, first and foremost, skills of the blacksmith and from that point of view it related to the arts.

In opposite to its practice, the theoretical grounds, which roots are deep in to two fundamental sciences – the continuum mechanics and metal physics – are relatively young and have been developing very intensively. It might hold that the theoretical fundament has been laid during the last (twentieth) century, especially in the time span 1950 and 1990 when the full blossom has been reached. If we agree, that the number of the publications

appeared in the specialized magazines as a measure of the interest paid by the researchers to the hot-closed-die forging in the last decade of the past century an evident, declination will be noticed. This tendency is depicted on Fig. 1.

The trend lines let a hint additionally that the scientific capacity is also dropping down. The same phenomenon we might observe in the very beginning of the 21-st century. This draws a hasty conclusion: the end of the forging technology has come. Engineers reach to the optimum, and further development will serve only to support the level reached. And this will be thoroughly wrong! Forging has unique position among manufacturing processes. One may apply it for almost all metals, alloys and powder metal components. In addition, it is the only process allowing both, not only a new shape, but also changing the mechanical properties of the component. The components produced through forging, in fact do not have restrictions in mass and dimensions, the punctuality both of the dimensions and

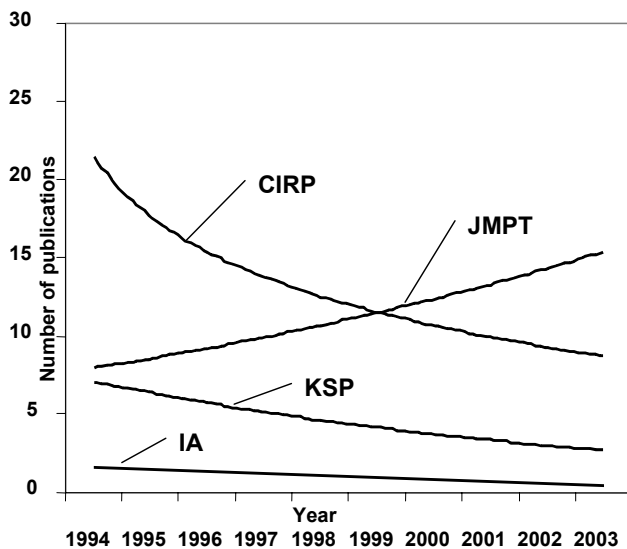

Fig. 1. Number of the publications, which object is hot closed-die forging (HCDF) published, during the last 10 years in: Industrie - Anzeiger - IA / Germany; Annals of the CIRP - CIRP / France; Journal of Materials Processing Technology - JMPT / The Netherlands; Кузнечно-штамповачное производство - KSP / Russia

surfaces satisfy the nowadays requirements, and at the same time the strength and the fatigue toughness undergo significant improvement.

It is thru, that forging industry faces serious challenges as:

- 1) The globalization of the economy continues to increase and it makes the competition very hard. "In order for the forging industry to remain viable and successful, there is a need for a comprehensive approach, through alliances, to support and address research and development programs for reducing costs and lead times and increasing material utilization." [3, 4,5];
- 2) Strong scientific schools in East- and Middle-Europe stop to act and the consequences were broken continuity of traditions. At the same time other researchers started from the very beginning;
- 3) There is a serious lack of new ideas and new technological schemes, which help to complete the requirements, said above in point 1.

This paper relying on achievements and original ideas worth attention but not thoroughly exploited, is to draw the reader's attention on the possibility to generate new technological schemes and in this way to better the products quality.

2. Material selection. Drawing of the forging part

The trend line in this field shows that ferrous and non-ferrous alloys, processed by the forging methods, which have been turned in to classics in forging industry, are, and pretty soon, will be replaced by new light-weight, higher-strength, and higher-quality

alloys able to compete with the other materials. New tool materials for forging and trimming dies will replace the classical ones. Most probably forging and trimming tools will be processed from bi-or three-metals, and thin layers of high wear resistance material will increase significantly the tools life.

As it is well known the flow stress and mechanical properties both of the slug and of the forging component may be significantly affected by changes in the strain rate, temperature and microstructure during the forming process, hence it is necessary to investigate all mechanical and physical properties of this alloys, allowing to calculate stresses, strains and strain rates during the forming process.

The new nano-materials will put new problems in front of the researchers. In my opinion the understandings about the mechanism of the plastic deformation will change seriously.

The stress strain relation or flow curve is generally obtained from a compression test. However these tests have some limitations [3] and they must to take in to account.

Briefly said, due to appearance of new materials a lot of researches, allowing to gain knowledge about the necessary technical characteristics have to be done.

2.1. Drawing of the forged component

The forging component differs from the end-form with the machining allowances, which are additional amount of metal, foreseen for assurance the dimensions and shapes punctuality of the end-form. Naturally, the real process of production requires also proper tolerances. Both, allowances and tolerances depend upon a lot of factors, such as:

$$MA = f(KM, S, Li, Ra, PH, DW, EDD, EDM) \quad (1)$$

$$TDS = \varphi(KM, S, Li, PH, DW, EDD, EDM) \quad (2)$$

where:

KM – kind of material;

$S = m_F/m_{CB}$ - the von Spies ratio: m_F is the mass of the forging component, and m_{CB} is the mass of the body circumscribing the forging component. The circumscribing body is prisma or cylinder;

L_i – the dimensions;

Ra – the surface roughness;

PH –heating conditions;

DW – die wear;

EDD – elastic deflections (displacements and rotations) of the die;

EDM – elastic deflections (displacements and rotations) of the machine.

Machining practice has shown that the allowance consists from three fractions:

$$MA = MA_R + MA_C + MA_F \quad (3)$$

here:

MA_R – fraction for rough or primary machining;

MA_C - Fraction for clean or secondary machining;

MA_F - fraction for finishing machining.

Machining practice has shown, that the MA_C and MA_F do not change being $MA_F = 0,25$ mm and $MA_C = 0,5$ mm. Only surfaces that are subjected on grinding, both flat or profile will have MA_F . Hence, the progress in closed die forging is a consequence of decreasing MA_R . Measures resulting in improvement of one or more of the above mentioned factors aimed at reducing MA_R is a step improving the quality of the forged component.

2.2. Near nett-forming

The near-nett closed-die forging belongs to the most applicable processes. The reason is smaller machining allowances, smaller tolerances and due to that better coefficient material utilization (KMU):

$$K_{MU} = \frac{m_0}{m_F} \quad (4)$$

where:

m_0 is mass of the end-component;
 m_F is mass of the forging component.

If $(MA)_1$ and $(MA)_2$ are the machining allowances of the existing technology (1), and the new one (2) We can define the precise (or near-nett) forging as set of measures, which affect improvement of one or more of the above mentioned factors, and due to that the relative difference Δm (5) diminish to zero while ΔMA and $\Delta T_{D,S}$ are about one.

$$\begin{aligned} \Delta m &= 1 \frac{m_0}{m_F} \rightarrow 0: \\ \Delta MA &= 1 \frac{(MA)_2}{(MA)_1} \rightarrow 1 \\ \Delta T_{D,S} &= 1 \frac{(T_{D,S})_2}{(T_{D,S})_1} \rightarrow 1 \end{aligned} \quad (5)$$

Completing conditions (5) could not be enough in some very peculiar cases, when in addition to the other aspects closed dies are required for the precision forging of parts without burs. May be the best examples for near-nett forging are different kinds of gears – straight, conical and helical, forged together with the tooth development [7,8,30]

3. Intermediate forming operations

However the variety of forging parts is enormous, the vast majority of these parts related to three main groups: I-st - bodies with a longitudinal shape, hence the deformation conditions related to plain strain one; II-d - bodies of revolution which related to an axis symmetric stress and strain conditions; and III-d longitudinal components subjected on bending. The transformation of the slug in to a final forged component is a result of proper sequence of forging, which, depending upon the shape complexity, requires interstage impressions, mainly

guttering, edging and blocking for the first group, flat or profile upsetting and blocking (or pre-forming) for the second group. Relatively little quantitative information is available on that topic. Only the designers with very extensive experience perform the task pre-form design [1,2,3].

3.1. The pre-form (blocker impression)

Pre-form impression allows adequate metal distribution in the final impression. Thus, defect-free, complete die fill and small metal loses into flash can be achieved.

It is shown [25] that proper perform design is the way to realize this process.

Two questions expect answer –is there any need of pre-form component and how to design its shape? A criterion called shape complexity factor (SCF) satisfies the first question. Only two approaches present in to the literature. According to the first one, proposed by G.P. Teterin [25] is calculated from:

$$(SCF)_F = \frac{\left(\frac{P^2}{A}\right)_F}{\left(\frac{P^2}{A}\right)_C} \cdot \frac{2R_{GF}}{Rg_C} \quad (6)$$

and

$$(SCF)_0 = \frac{\left(\frac{P^2}{A}\right)_0}{\left(\frac{P^2}{A}\right)_{co}} \cdot \frac{2R_{co}}{R_0} \quad (7)$$

here P, A and R are perimeters, areas of the vertical sections of the forged component and circumscribed cylinder and radii of the gravity centers of the component and cylinder. The indexes “F”, “C” and “0” refer to the forging component, circumscribed cylinder and the slug dimensions, respectively.

If

$$\frac{(SCF)_F}{(SCF)_{PRE\ FORM}} \geq 1 \quad (8)$$

a pre-form impression will present in the sequence of forging.

The Teterin’s criterion has some shortcomings, such as:

- It is a result of an expert assessment, therefore it will have limitations – in fact it is applicable for the axis symmetric forging components only;
- Very important shortcomings is that almost in every one case, the satisfying of the Teterin’s criterion entails two or even more pre-form impressions, which contradicts to the forging practice.

An other approach described B. Tomov [29]. It works on the assumption, that we can calculate the work done when an arbitrary component is forged:

$$W_F = [\sigma_{Y,T}] \cdot (V_m \ln \frac{A_F}{A_0} + V_{AD}) \quad (9)$$

The total amount of the work consists of two parts – work done for upsetting - $W_U = [\sigma_{Y,T}] \cdot (V_m \ln \frac{A_F}{A_0})$, and work done for

extrusion (or squeezing) - $W_E = [\sigma_{Y,T}] \cdot V_{AD}$

In order to draw a criterion, (9) must be transformed in a dimensions-less equation and compared with the work done for upsetting the so-called equivalent which diameter is equal to D_F and the height – to H_{AV} , therefore:

$$W_F^* = (1 - K_1) \cdot \varphi_A + K_1 \geq \varphi_H \quad (10)$$

$$\text{here: } K_1 = \frac{V_{AD}}{V_0}, \quad \varphi_H = \ln \left(\frac{H_0}{H_{AV}} \right) \text{ and } \varphi_A = \ln \left(\frac{A_F}{A_0} \right)$$

V_{AD} is the volume squeezed in impression cavities, V_0 - the volume of the forged component, A_F – forging area in the parting plane, A_0 – the cross-section of the slug, H_0 – the height of the slug and H_{AV} - the height of a cylinder, which volume is equal to V_0 and diameter $D_{AV} = D_F$ (see Fig. 2a).

The relation (10) is the criterion allowing estimating the necessity of a blocker impression: The bigger is the work done for extrusion the bigger necessity of a pre-form impression exists.

If we suppose that the cross-section of the pre-form is almost equal to the forging component cross-section, the criterion (10) simplifies turning in to:

$$K_1 \geq \varphi_H \quad (11)$$

Criteria (10) and (11), shortly “ $K_1 - \varphi_H$ ” criteria, are suitable for forged components from I-st and second group and they fit much more to the forging practice, as the calculations proved.

3.2. Designing the shape of the pre-form

The second question regards the shape of the perform component. Relatively many approaches are described in magazines: starting with the early works [1,6,13,14,29]. Some other, much more modern approaches [21,23,24,32] could be found also.

A very clever solution, concerning the pre-form design, has been found by Zhao G., and co-authors [33]. They apply a method, which employs an alternative boundary node release criterion in the FEM simulation of a backward deformation of forging processes. The method makes use of the shape complexity factor, which provides an effective measure of forging difficulty. The objective was to release the contacting nodes in a sequence, which will minimize the geometric complexity throughout the backward deformation simulation. This is done by calculating the

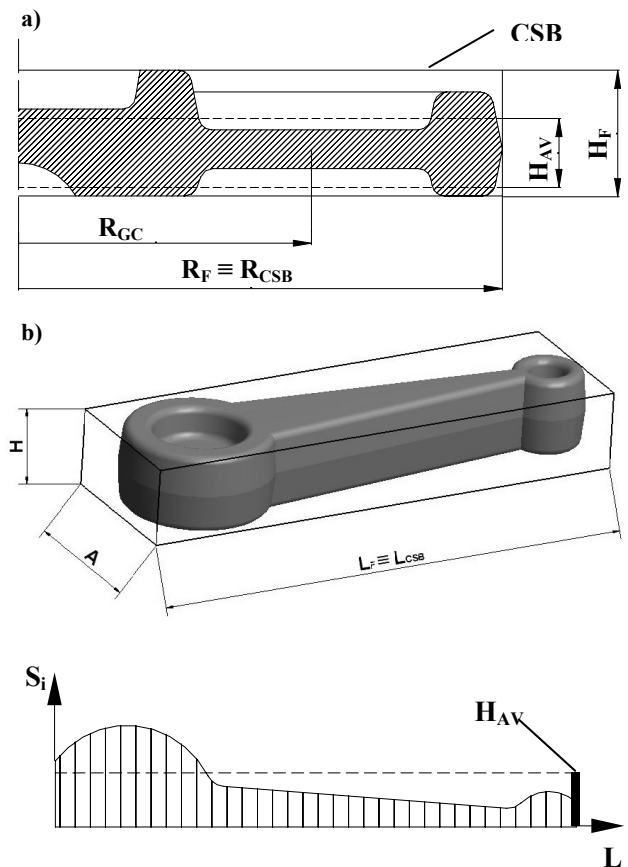

Fig. 2. Dimensions of a body of revolution of forging component from II group (a) and forging component from I group (b), allowing to calculate SCF both according [25] and [36]:

H_F – forging component maximum height

R_{GC} – radii of the gravity centre

effect of releasing each of a select group of boundary element nodes at each FE solution step. This process continues for each backward step until the last few nodes remain in contact.

An other approach demonstrated Oh, S., L. and co-researchers [21]. In their opinion a prime concern in closed die forging is to ensure the complete filling of the die cavity at minimum costs, with no defects, and reduced die wear. Hence, it is necessary to predict the material flow behaviour in advance of carrying out the final operation. For the purpose said, the authors make use of UBET (Upper Bound Elemental Techniques). Unfortunately, UBET do not allow to calculate all process parameters, especially appearance of some common defects.

Biba [5] and co-authors developed FORM-2D- system and its applications to analysis and treat two-dimensional (plane and axis-symmetric strain) deformation of metals, super plastic alloys, powder material glasses and polymers. It can be applied to simulation and analysis of closed-die forging, extrusion, upsetting, turbine blade forming, powder compacting and some other technological processes. The system provides interactive perform and die design, coupled with thermo-mechanical simulation of material flow, graphical output of

the results and supports an interface to CAD/CAM systems. The system includes integrated Smart Mesh Generator (SMG) that provides completely automatic finite element mesh generation at each time step. The adaptive algorithm, implemented in such as laps, flow through and suck-in defects, unfilled die corners and surface chilling can be predicted and avoided by correction of technological parameters in interactive mode

4. Combining operations

Combining operations is a response to the acute need to reduce the costs of the forging components, preserving, or even bettering the quality. Taking in to account that the real temperature of the flash trimming and the wad piercing is about $1000 - 1050^{\circ}\text{C}$ it is easy to guess that finishing operations could coincide with forming ones. An example displaying that idea is depicted on Fig.3 [20], Fig.4 [20] and Fig.5 [20]. A relatively sophisticated forging component – see Fig.4d- with $K_1 \geq \phi_{1h}$, what means that this forging component requires a blocker, is replaced by a more simple – Fig.4a. Therefore the new variety don't require presence of blocker.

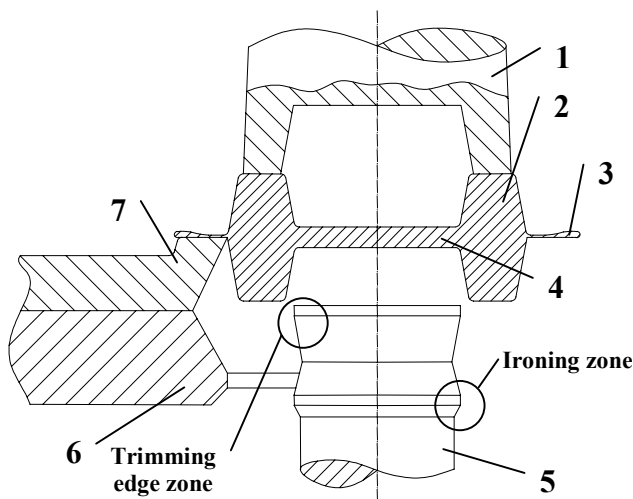

Fig. 3. Combining flash trimming and wad piercing with ironing. 1 – upper die; 2 – forged component; 3 – flash; 4 – wad; 5 – clipping punch; 6 – ironing bed; 7 – trimming bed

By the means of appropriate cooling of the forging part [11], the costs of the whole forging process may be reduced with 3-18%. If the cooling is in conditions of free convection, the mechanical properties could be essentially improved. Examined are R_E , R_m , A_5 , Z and A_V . Something more, the machining abilities increase decisively.

5. Exploitation of the active friction forces [19]

The meaning “active friction forces” is arbitrary one. It makes use from the friction forces, which better the forging process,

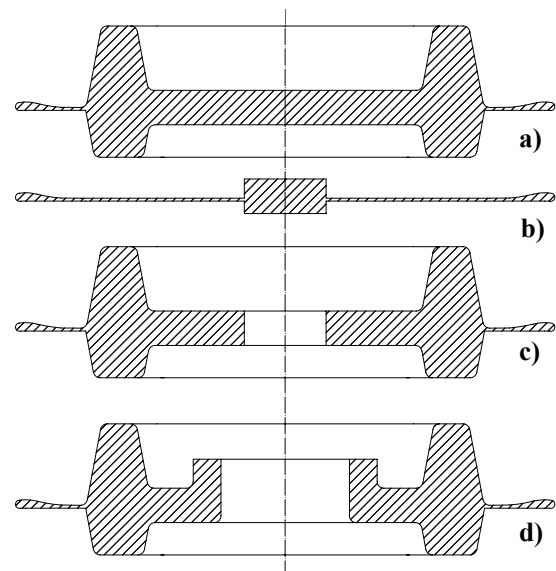

Fig. 4. Combining trimming and piercing with forming operations

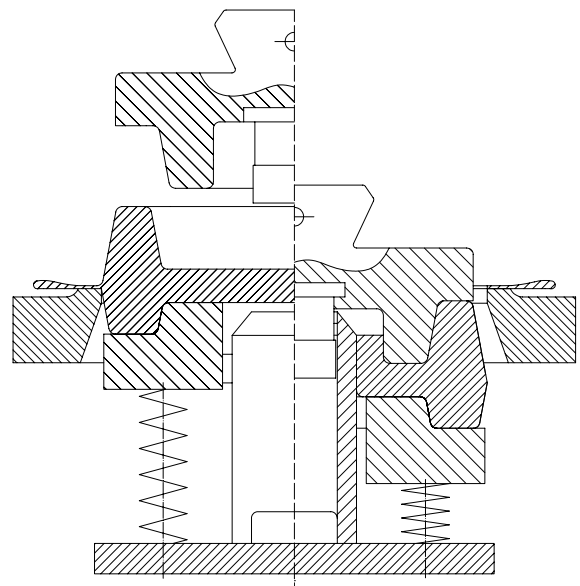

Fig. 5. Scheme of the trimming, piercing and forming tool for the component from Fig. 4

filling the die cavity without overloading. The example given on Fig.6 shows the case when the die for an axes symmetric forging component consists from three parts: 1– bed, 2 – swage, and a ring – 3. The last one closes the space of the die, allowing good filling of the die. At the end of the forging process the die is subjected on over loading which is realised due to the active friction force μP , and more precise by the component $\mu P \cos \alpha$. If $\mu P \cos \alpha > G$ where G is the gravity force exercised by the ring mass, the ring stars to move upstairs, opening the die space on a value h_f equal to the height of the flash land. Over loading

immediately drops down. The active friction forces could find numerous applications.

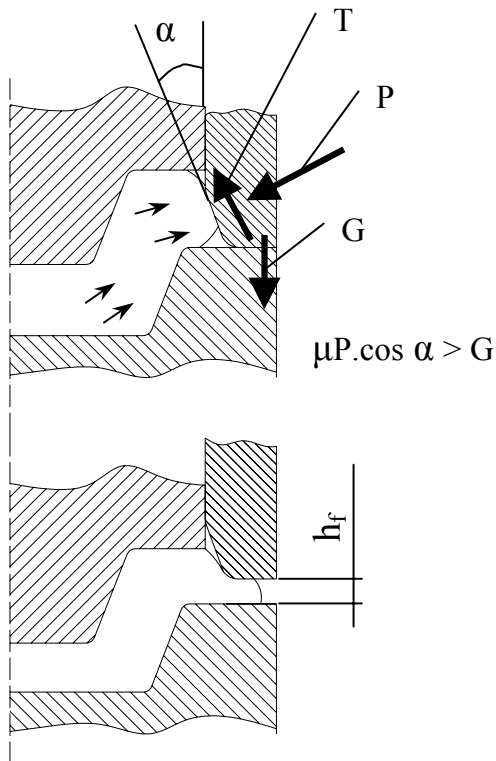

Fig. 6. Using of active friction forces for flash formation

6. Tools and press stiffness

Tools and press stiffness play significant role for how large are the real value of the machining allowances. Forging forces cause large deflections of the dies [16], die-packages [27], and machines [8,10,11,]. Up to date precision components such as bevel gears manufactured by warm and hot forging with a subsequent cold calibration for the determination of the exact geometry. A precision forging technology has been developed for manufacturing of bevel or cylindrical spur gears. Coining operation of the work pieces can be eliminated, which leads to considerable cost-savings. With the aid of FEM forging processes can be simulated realistically, thus reducing the number of necessary experiments. Up to date precision parts such as bevel gears are manufactured by warm and hot forging with a subsequent cold calibration for the determination of the exact geometry. The high demands on the precision of the work pieces produced by metal forming call for increasing standards of stiffness and accuracy of employed machines and become more relevant than ever [10,18]. A possible way to reach this goal is to optimize stress behavior and the flux of the forces in all components of the metal forming machines such as the high strained areas of guides or cross-heads with integrated drives have to be improved by means of scientific research.

7. Physical and numerical modelling

Physical and numerical modelling plays an important role in process planning affecting strongly on the possibilities of energy and material saving, and additionally assure flawless forging process [26,31]. Cheap model materials prepared carefully, satisfying the requirements and rules of similarity allow to investigate all processes of closed die forging, independent how complicated they are, thus physical modelling is a powerful tool for reducing the costs necessary.

Numerical modelling and simulation are the most applicable techniques in the last 15-20 years. The main objectives of the numerical process modelling bulk metal forming are [3]:

- to optimize die and process design;
- to assure the die fill and prevent defects;
- to predict and control the die life and die failure;
- to predict and control microstructure and properties of the formed part;
- to reduce the number of the operations needed,

The review of the literature and communication with the industry indicated that:

- In bulk metal forming 2D simulation is much more often applicable, and a grate deal of computer programs, could make use when forging process is to design. in bulk metal forming 2D simulation is well accepted by researchers as well by the industry.
- The application of 3D simulation continues to increase. However, due to present hardware, limitations, these applications are still are relatively rear and limited to some simple geometries.
- Numerical process simulation is capable of predicting microstructures and properties of the formed product. This application is expected to increase in the future.

8. Economical aspects of the research and development in CDF

The precision required of a forging component, could be also from the economical point of view considered. [12]. Innovation in forging shows not a smooth but a wavy flow. Each case is in a sense unique and its course cannot be forecast [9]. There are large number of possible combinations of the characteristic features and eventual emergence of one particular pattern can not be explained in general causal terms. The process tends to follow rules but these are only valid within the given organization; they cannot be deduced from the theory. Nevertheless, typology demonstrates that the combination, which may emerge can be assessed and this has implications at least for innovating companies official policymakers and future researchers.

9. Conclusions

The following conclusions from the above done review may be drawn:

- The HCDF technology is on the threshold of a new period of positive development. However some problems as

intermediate impressions, for example blockers, are exhausted, there are plenty others which require additional investigation.

- 2) Future research activities may be arranged in two groups: the first one will have more routine character accumulating data for the new materials; the second group will have more creative approach dealing with computer and physical modelling and simulation of the forging process.
- 3) Dies design seems to be the most interesting and creative realm of the process planning.
- 4) A lot of efforts is to be put in connections between economical and technical aspects of the forging process. Ideas as combining operations and exploitation factors realizing the forging process will play essential role in process design.
- 5) Process management has to be inseparable part of the technology

References

- [1] N. Akgerman, J.R. Becker, T. Altan, Perform design in closed-die forging, *Metalurgia and Metal Forming* (1973) 135-138.
- [2] T. Altan, D.N. Akgerman, Rechnergestuetzte Konstruktion und Fertigung von Schmiedegesenke zum Vor- und Fertigschmieden, *Industrie – Anzeiger* 96/34 (1974) 763-767 (in German).
- [3] T. Altan, V. Vazqes, Numerical process simulation for tool and process design in bulk metal forming, *Annals of CIRP* 45/2 (1996) 599-607.
- [4] K.J. Barnett, Research initiatives for the forging industry, *Journal of Materials Processing Technologies* 98 (2000) 162-164.
- [5] G. Zhao, E. Wright, R.V. Grandhi, Computer aided perform design in forging using the inverse die contact tracking method, *International Journal of Machine Tools & Manufacturing* 36/7 (1996) 755-769.
- [6] S.K. Biswas, W.A. Knight, Preform design for closed-die forgings: Experimental basis for computer aided design, *International Journal of Machine Tool Design and Research*, 15 (1975) 179-193.
- [7] E. Doege, R. Bohnsack, Closed die technologies for hot forging, *Journal of Materials Processing Technologies* 98 (2000) 165-170.
- [8] E. Doege, H. Naegele, FE simulation for precision forging process of bevel gears, *Annals of the CIRP* 43/1 (1994) 241-244.
- [9] N.C. Duffy, Technomorphology, Innovation and Energy Analysis: II Analytical Methods, *Journal of Materials Processing Technologies* (1983) 349-371.
- [10] E. Doege, G. Siberbach, Influence of various machine tools components on workpieces quality, *Annals of the CIRP*, 31/1 (1990) 209-213
- [11] P. Fascher, Vereinfachung der Waermebechndlung durch gesteuertes Abkuehlen, *Industrie Anzeiger* 5 (1982) 23-25.
- [12] G. Hartke, B. Adams, U. Weiss, Konzeption eines Werkzeugsystem zum Prezisionschmieden (1987) 12/1-12/13.
- [13] K. Hyunkee, T. Yagi, M. Yamanake, FE - Simulation as a must tool in cold/warm forging process tool design, *Journal of Materials Processing Technology* 98 (2000) 143-149.
- [14] Y.K. Heon, W.K. Dong, Computer aided pre-form design in the closed die-forging process, *Journal of Materials Processing Technology* 41 (1994) 83-104.
- [15] M. Herrmann, M. Wilhelm, P. Keck, Process simulation of metal-forming processes: some examples, *Annals of the CIRP* 40/1 (1991) 285-289.
- [16] D.H. Hristov, B. Tomov, D.K. Kolev, Stresses and strains in a die for closed-die forging of cylindrical spur gears, *Journal of Materials Processing Technology* 23 (1990) 55-63.
- [17] K. Lange, Modern metal forming technology for industrial production, *Journal of materials processing technologies* 71 (1997) 2-13.
- [18] T. Jimma, F. Sekine, Effect of rigidity of die and press on blanking accuracy of electronic machine parts, *Annals of CIRP* 41/1 (1992) 319-322.
- [19] A.N. Levanov, N.I. Volosov, V.I. Lukin, The use of the active friction forces in a closed die, *Kuznecno – shtampovochnoe proizwodstvo* 2 (1981) 4-6 (in Russian).
- [20] V.K. Lobanov, S.P. Ponomarenko, Combined timming and forming operations, *Kuznecno – shtampovochnoe proizwodstvo* 8 (1978) 8-10 (in Russian).
- [21] S.I. Oh, S.M. Yoon, A new method to design blockers, *Annals of the CIRP* 43/1 (1994) 245-248.
- [22] S.I. Oh, W.T. Wu, K. Arimoto, Recent developments in process simulation for bulk forming processes, *Journal of Materials Processing Technology* 111 (2001) 2-9.
- [23] F.H. Osman, A.N. Bramley, Preform design for forging rotationally symmetric parts, *Annals of the CIRP* 44 (1995) 227-230.
- [24] S. Sun, L.Y. Guo, A die forging design approach for controlling metal flow way and application in practice, *International Journal of Machine Tool Design and Research* 34/2 (1994) 161-167.
- [25] G.P. Teterin, I.J. Tarnovskij, A.A. Chechik, A shape complexity criterion, *Kuznecno – shtampovochnoe proizwodstvo* 7 (1966) 6-9 (in Russian).
- [26] B. Tomov, T. Wanheim, Preform design, based on model materials, *Proceedings of AMTECH '93*, 1993.
- [27] B. Tomov, D.K. Kolev, About the thickness of the die-sets plates for closed die forging on crankshaft presses, *Kuznechno – shtampovochnoe proizvodstvo* 4 (1988) 4-6.
- [28] B. Tomov, K. Chodnikiewicz, A mechanical device for measuring displacements and rotations of a blanking or forging press, *Journal of Materials Processing Technology* 77 (1998) 70-72.
- [29] B. Tomov, A new shape complexity factor, *Journal of Materials Processing Technology* 92-93 (1999) 439-443.
- [30] T. Wanheim, J. Dankert, E. Jonson, Anwendung der Modeltechnik bei Masivumformungsvogaengen, *Industrie Anzeiger* 70 (1977).
- [31] T. Wanheim, J. Dankert, Model material technique applied in analyses of forging of a specimen of complicated shape, *Scandinavian Journal of Metalurgy* 6 (1977) 185-190.
- [32] W.T. Wu, J.G. Li, J.P. Tang, Finite Element Analysis of three-dimensional metal flow in cold and hot forming processes, *Annals of the CIRP* 43/1 (1994) 235-239.
- [33] G. Zhao, E. Wright, R.V. Grandhi, Forging perform design with shape complexity control in simulating backward deformation, *International Journal of Machine Tools & Manufacturing* 35/9 1225-1239.