

Model reference-based machining force and surface roughness control

F. Cus, U. Zuperl*

Faculty of Mechanical Engineering, University of Maribor,
Smetanova 17, 2000 Maribor, Slovenia

* Corresponding author: E-mail address: uros.zuperl@uni-mb.si

Received 24.04.2008; published in revised form 01.08.2008

Manufacturing and processing

ABSTRACT

Purpose: The main objective of this paper is to present the development of an empirical model-based control mechanism to maintain a fine surface finish quality by maintaining on-line cutting values.

Design/methodology/approach: The proposed model has been developed to present the control model constraints, by varying the machining parameters to control the force output to be constant. Genetic programming method (GP) has been applied to derive empirical relationship of the surface finish and the cutting force. These relationships have been applied to develop the proposed simulation model, in which the cutting force is adjusted to improve the required surface finish for the end milling operation process.

Findings: The experimental results show that not only does the milling system with the design controller have high robustness, and global stability but also the machining efficiency of the milling system with the adaptive controller is much higher than for traditional CNC milling system. Experiments have confirmed efficiency of the adaptive control system, which is reflected in improved surface quality and decreased tool wear.

Research limitations/implications: The proposed architecture for determining of optimal cutting conditions is applied to ball-end milling in this paper, but it is obvious that the system can be extended to other machines to improve cutting efficiency.

Practical implications: The results of experiments demonstrate the ability of the proposed system to effectively regulate peak cutting forces for cutting conditions commonly encountered in end milling operations. The high accuracy of results within a wide range of machining parameters indicates that the system can be practically applied in industry.

Originality/value: By the GP modeling the system for adaptive adjustment of cutting parameters is built.

Keywords: Machining; Model-based control system; Genetic programming

1. Introduction

The control of milling processes is presently receiving significant attention due to potential economic benefits associated with automated machining [1]. Milling processes are interesting from a control perspective due to difficulties such as system nonlinearities, time-varying parameters and tool wear [2,3]. Control techniques that have been developed for machining traditionally require some form of parameter adaptation [1,4]. Solution to this problem is adaptive control. Adaptive control system is introduced in cutting process by Stute and Goetz [5]. The most frequently used systems are MRAC (Model Reference

Adaptive Control) [6] and STR (Self Tunning Regulations) [7]. MRAC, developed from adaptive control theory, is widely used for its robustness and disturbance rejection capability. Numerous forms of MRAC system have been developed [8,9].

Another solution to this problem are some intelligent control strategies [1]. The drawback of intelligent strategies is that neural network and genetic algorithm based calculation takes time, so it limits the response of the intelligent control system. In spite of initial difficulties in the development a trend towards equipping the CNC milling machine with modern adaptive systems can be noticed. For effective automatization, where the process takes place without interference of the human, continuous monitoring

of the milling process is necessary. Most frequently that is materialized by measuring the cutting forces because they contain most information about the process and the tool condition. By analyzing the cutting force characteristics it is possible to assess the changes of the quality of surface finish [10]. The abovementioned facts are the bases for the development of the model based system for dynamic adjusting and optimization of cutting parameters (SDNRP). That is an adaptive system of control which controls the cutting force and maintains constant roughness of the machined surface during milling by continuous dynamic adjustment of the cutting parameters. Within the frame of the research a simulation model for testing of stability and harmonizing of parameters of the adaptive system (SDNRP), has been developed. The SDNRP changes its reactions in response to disturbances and changes in the dynamics of the cutting process. After execution of simulations the system SDNRP is fully ready and harmonized for the use in real milling process. The simulation diagram of the proposed system is presented in section 5.

2. Model based milling process control

Model based control system is a regulator that can modify its behaviour in response to change in the dynamics of the process and the disturbances. If the cutting force maintained constant during the process of machining process, then the surface finish also remain stable. In the previous research work [11] the cutting force resultant is obtained using a Kistler force Transducer, which provides of three orthogonal components of dynamics forces F_x , F_y , F_z and these forces were measured on-line using LabView software. These measured cutting force signals are used in model controller to regulate the cutting force. The main objective of this research is to develop genetic model based control system, which can solve such difficult machining control problems.

The objective of the proposed control system is to regulate the milling process operation parameters such as the feed rate and the spindle speed, and maintain the cutting force constant, to achieve on-line the required value of the surface finish. The Heller BEA01 milling machine was used in connection with the feed drive controller

3. CNC machine feed drive system

The tests were carried out on the CNC milling machine Heller. That is a four-axes machine tool allowing 3 translations along the X, Y and Z- axis and rotation of machine table in the horizontal plane. It is fitted with CNC controls FAGOR 8040-M. Feeding axles are driven through ball screw drives by AC servomotors synchronized with permanent magnets. The type of the servo-drive is: Heller S 044/82 8-A20-2220-001/02C. The block diagram (simulation model) of the feeding servo-system is shown in Figure 1.

4. GP based models of cutting quantities

Learning of models of cutting quantities is effected with experimental results stated in previous researches [12]. The

purpose of models is to define functional dependences between the influencing cutting parameters: spindle speed, surface roughness and cutting force. The genetic programming (GP) method is used for the determination of mutual relations between the rotating speed and feeding and between cutting force and roughness. In case of GP the result is the mathematical formula consisting of a series of prescribed operations.

In simulations the GP models are used because, in the simulation package Simulink, they can be easier transformed into the block recording. 185 experimental data are used to develop each genetic model. The experimental datum contains the value of the predicted (modelled) quantity and the appurtenant influencing parameters (cutting parameters). On the basis of the input and experimental data and with selected series of calculation operations the models: K1, K2, K3, K4, K5 = K6 are generated. The series of the following basic calculation operations $\mathcal{F} = \{+, -, *, \div, \ln\}$ and arguments $\mathcal{P} = \{2, 2, 3, 2\}$ is selected. The set of terminals (\mathcal{T}) is given beside the block diagram of the individual model. Usually, the set of terminals consists of input data and variables of the system.

The size of the population of organisms $M = 1500$ and the number of generations $G = 100$ have been selected for the determination of the model of cutting (K4). On other models $M = 850$ and $G = 100$. The standard genetic operations of reproductions, crossover and mutation have been used. The reproduction probability $p_r = 0.15$, the crossover probability $p_c = 0.5$ and the mutation probability $p_m = 0.1$. The development of the model is stopped when the prescribed number of generations has been reached or when fitness of the organism is more than 97 %.

4.1. Derived GP models of cutting quantities

Prior to any machining the required quality of the surface finish (R_a) is known. The equation herebelow gives the cutting force (F_d) with which the required surface roughness is reached and maintained. For the model parameter F_d the following formula has been formed according to the GP method:

$$F_d = 293 - \frac{593}{\sqrt{39.37 \cdot R_a}} \quad (1)$$

The following two GP models are in use for the determination of optimum cutting parameters:

$$f = 25.4 \cdot \left(189 - \frac{5926160}{F^2} \right) \quad (2)$$

$$n = \sqrt{(30064193 - 2.28 \cdot F^3)} \quad (3)$$

Where: f – feed rate [mm/min], n – spindle speed [min^{-1}].

The parameters with which the required surface roughness (R_a) is assured are determined according to the above equations. The objective of the SDNRP is to assure constant cutting force F . The following formula (model parameter K4) is used for simulation of the cutting process.

$$F = 286.44 - \left(\frac{5.82}{10^{10}} \right) \cdot n^3 - 8973 \cdot \frac{\ln(0.039 \cdot f)}{f} \quad (4)$$

Surface roughness is tested according to the following equation:

$$R_a = 0.0254 \cdot \left(\frac{593}{293 - F} \right)^2 \quad (5)$$

Where: R_a : surface roughness [μm], F : cutting force [N].

5. Simulator of SDNRP

The block diagram of the simulator of the SDNRP is shown in Figure 2. If in the block diagram the model K4, the simulation model of the feed servo-drive and the model of main spindle rotation are replaced by the real machine tool, a harmonized system for dynamic adjustment of cutting conditions, ready for

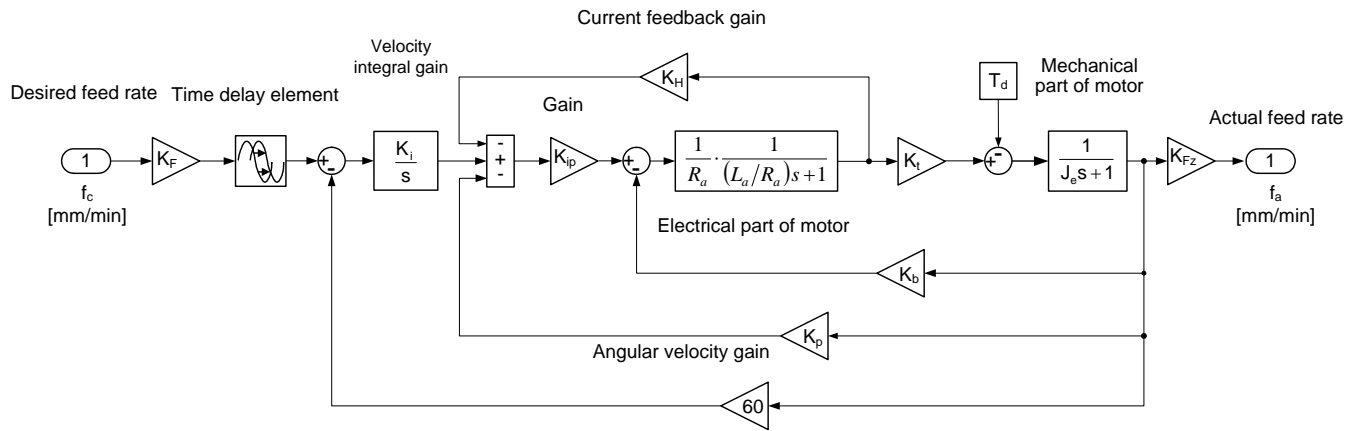

Fig. 1. Block diagram of feed drive servo system

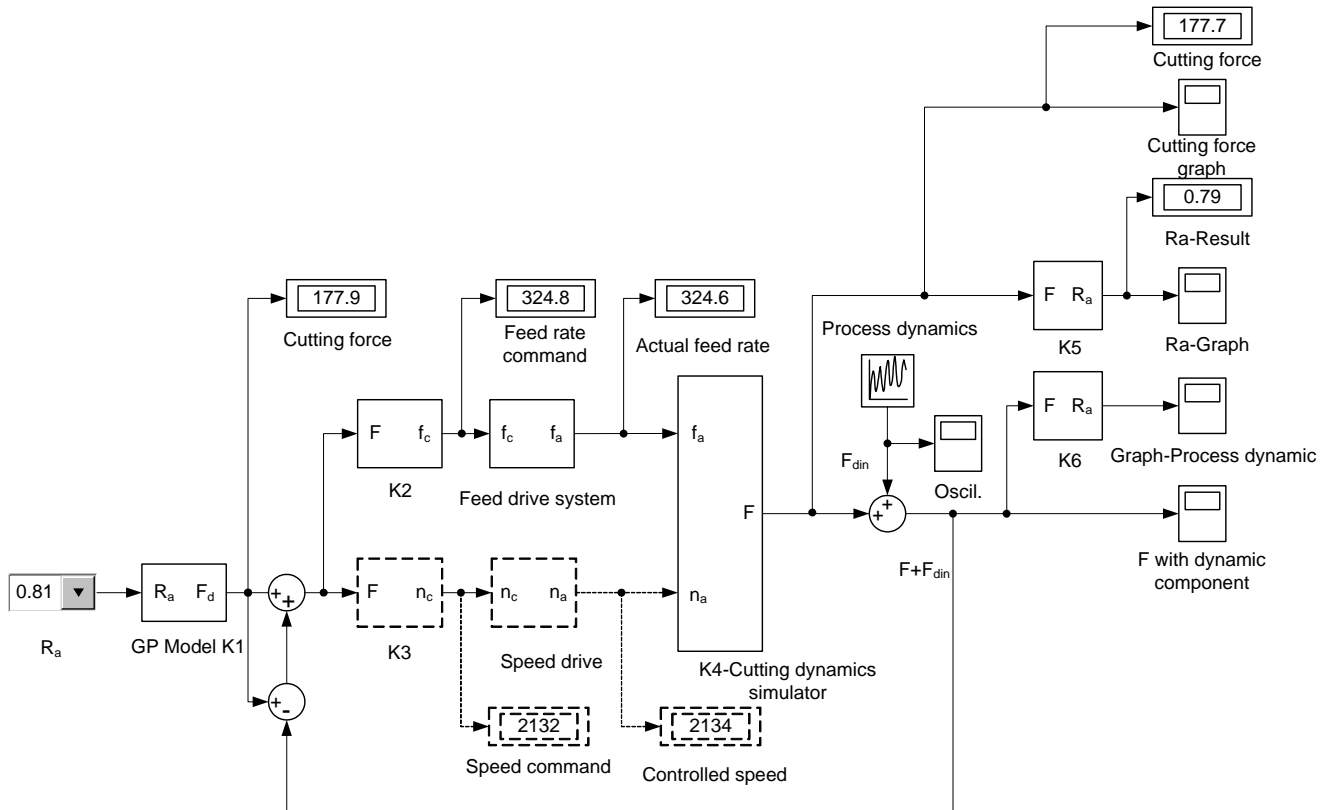

Fig. 2. Block diagram of the system for dynamical adjusting of cutting parameters. (Control system block diagram)

immediate use, is obtained. The system with regulation of the cutting force assures the required surface roughness. The block diagram of the transfer function of the feed servo-drive is shown in Figure 3. The simulation diagram comprises: simulator of CNC controls, simulator of the feed and main servo-drive, simulator of cutting, reference block and the models determining the mutual relations between the influencing cutting values.

The simulation models of the machine dynamics are made on the basis of the technical specifications of the maker Heller.

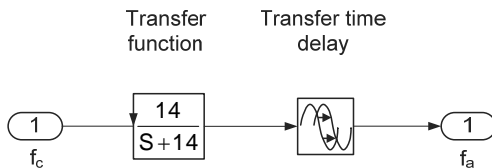

Fig. 3. Feed drive servo system transfer function

Hereinafter, the transfer functions of the individual elements of the SDNRP and the flow of signals between them are presented in detail.

K1: Figure 4 shows the transfer function defining the dependence between the desired surface roughness and the appurtenant cutting force F_d . The transfer function is given in the form of the block diagrams. Modelling is effected with the standard set of blocks in the programme package Matlab 6.5. The set of terminals: $\mathcal{S} = \{R_a, F_d, \mathcal{R}\}$ is used. \mathcal{R} - real number at the interval from -10 to 10.

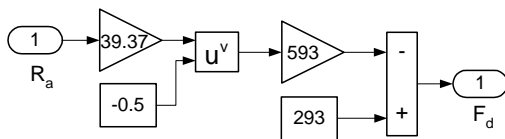

Fig. 4. Block diagram for relation surface roughness-cutting force

K2: Transfer function for prediction of optimum feeding f_c is derived according to equation 2. Figure 5 shows its block diagram. $\mathcal{S} = \{F, f_c, \mathcal{R}\}$.

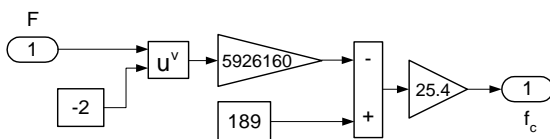

Fig. 5. Block diagram for relation cutting force – feed rate f_c

K3: The relation between cutting force F and the command signal n_c is expressed by the transfer function derived according to equation 3. The transfer function is shown in Figure 6. Its purpose is to generate continuously the command signal of the rotating speed n_c . $\mathcal{S} = \{F, n_c, \mathcal{R}\}$.

K4: The transfer function presented in Figure 7 represents the simulation model of the cutting process. By the block diagram the

value of the actual cutting force on the tool cutter with given cutting conditions is predicted. $\mathcal{S} = \{n_a, f_a, F, R\}$.

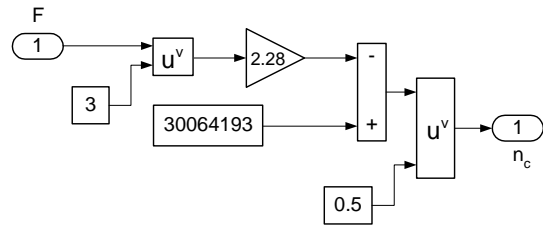

Fig. 6. Block diagram for relation cutting force – spindle speed n_c

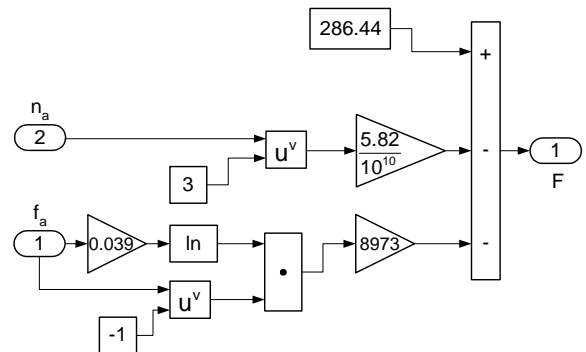

Fig. 7. Block diagram for relation cutting force – spindle speed n_c

K5, K6: By the block diagram it is tested whether the simulated R_a corresponds with the desired R_a . The test procedure is shown in Figure 8. $\mathcal{S} = \{F, R_a, \mathcal{R}\}$.

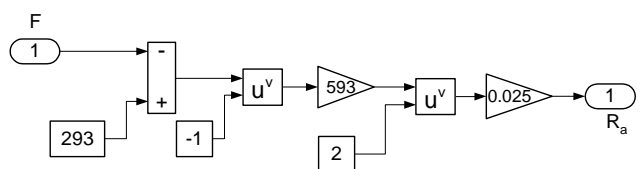

Fig. 8. Surface finish inspections block diagram

During the machining process undesirable vibrations and disturbances occur. They are caused by: nonhomogeneity of the base material, tool wear, tool damages, defects in guides and bearings of the machine etc. By introducing the random disturbances into the simulation the stability and robustness of the proposed control system are tested. In the simulation model the unmodeled dynamics of the process is generated by random values corresponding with oscillations of the measured cutting forces. The diagram in Figure 9 simulates the unmodeled dynamics of the machine and process.

During the simulation the following values are drawn in the diagrams of the control console:

- Actual surface roughness,
- Surface roughness with the considered machine tool dynamics
- Maximal cutting force,

- Maximal cutting force with the dynamical component,
- Actual feeding,
- Actual spindle speed.

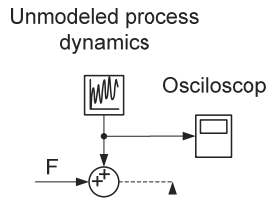

Fig. 9. Block diagram for relation cutting force – spindle speed n_c

5.1. The realization course of SDNRP simulation

The SDNRP capacity is tested by simulations. The Matlab simulation package Simulink has been used. The simulation is initiated by the adjustment of the reference value R_a , afterwards desired cutting force F_d is predicted according to the model K1. When the force F_d is known, the values F_c and n_c are calculated within a moment according to the model K2 and K3. The dynamic response of the servo-system to the signal f_c is simulated by the block diagram given in Figure 1. The two transfer functions of the servo-systems generate the actual feeding (f_a) and speed (n_a) so that the cutting force, predicted according to model K4, is constant. The simulated R_a is determined by the transfer function of the model K5.

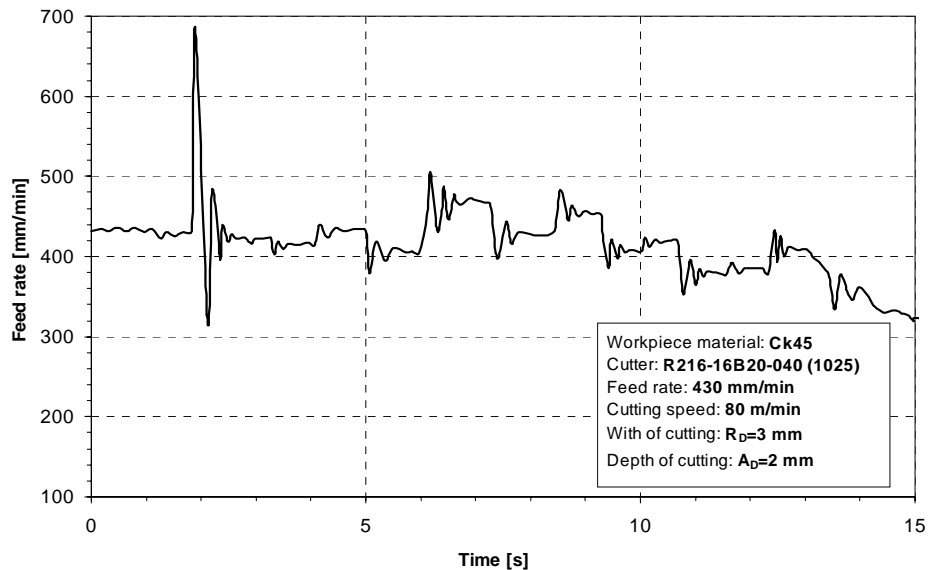

Fig. 10. Dynamical adjusting of feed rate during simulation

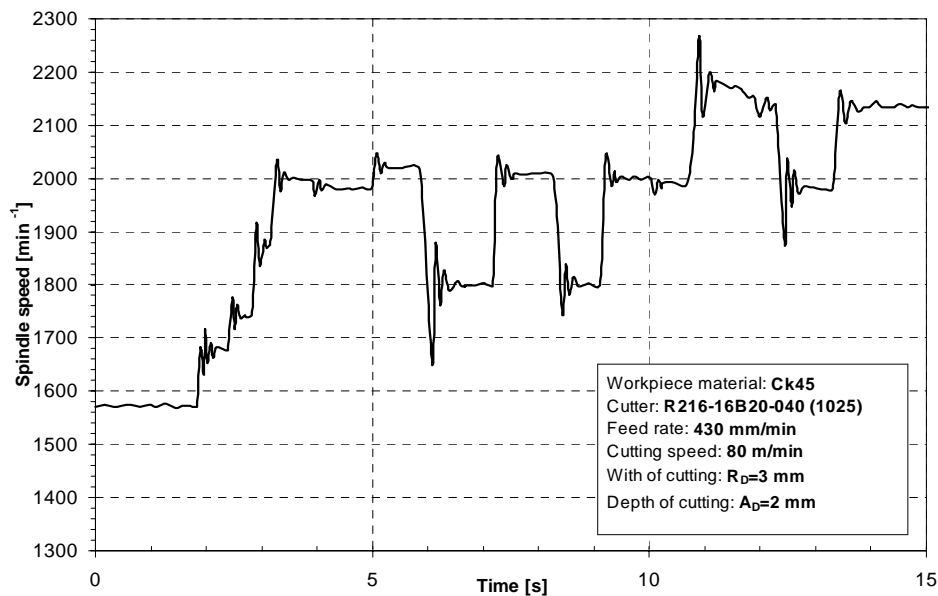

Fig. 11. Dynamical adjusting of spindle speed during simulation

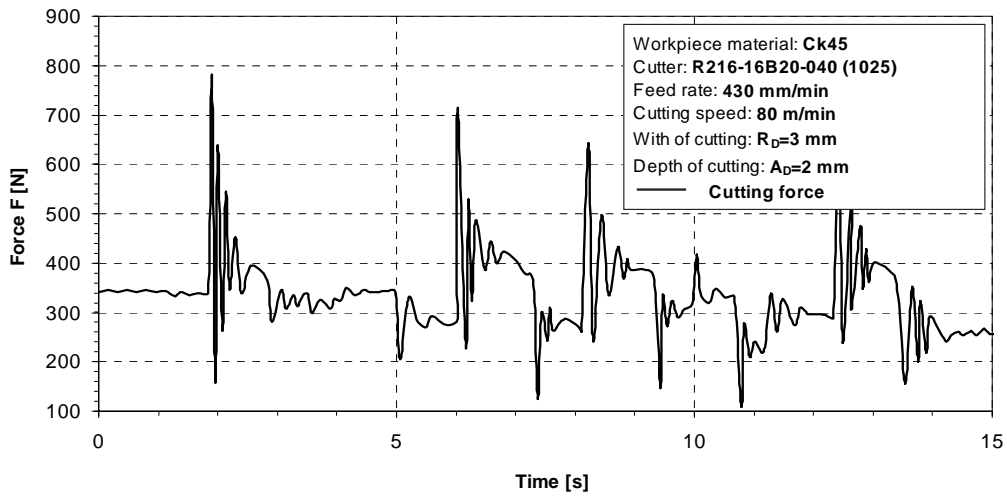

Fig. 12. The course of cutting force without application of SDNRP

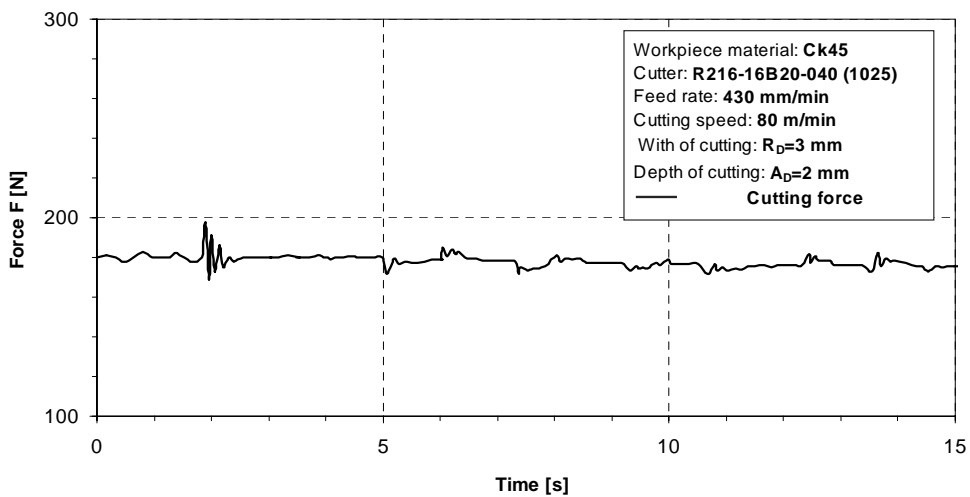

Fig. 13. The course of cutting force with dynamical adjusting of cutting parameters

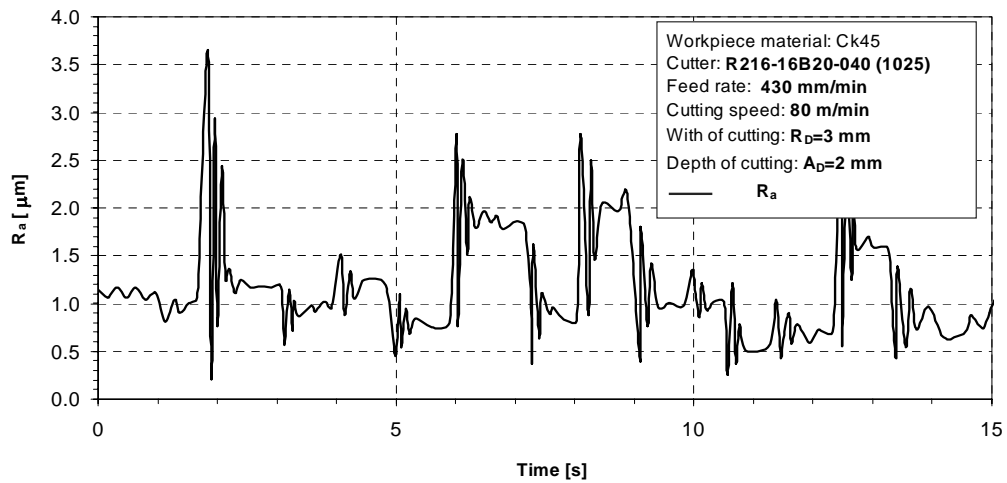

Fig. 14. Surface roughness before using proposed control system

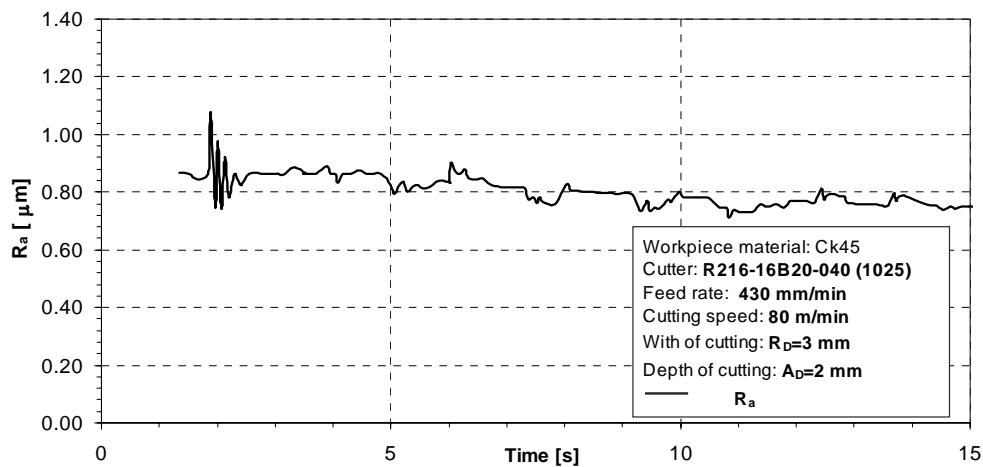

Fig. 15. Surface roughness after using proposed control system

6. An example of realized SDNRP

Hereinafter, the simulation No. 5 (table 2), effected for material Ck45 and milling cutter R216-16B20-040, is presented. The selected reference roughness is $0.81\mu\text{m}$. The starting optimum cutting parameters are determined by the PSO (Particle Swarm Optimization) algorithm [3]. They are given in Table 1. The simulation result is shown in the block diagram of Figure 2. The initial value of feeding is 430.4 mm/min . The system is changing that value, until optimum feeding 324.6 mm/min has been reached. The optimum final spindle speed is 2134 min^{-1} . Dynamic adjustment of feeding and spindle speed is a prerequisite for maintaining constant maximum cutting force of 177.7 N . The simulation result is the roughness $0.79\mu\text{m}$ which is acceptable if compared with the desired value $0.81\mu\text{m}$ (Figure 15).

Table 1.

Initial starting cutting conditions

$v_c = 80\text{ m/min}$	$R_D = 3\text{ mm}$
$f = 430.4\text{ mm/min}$	$A_D = 2\text{ mm}$

The process of simulation is shown in Figure 10 and Figure 11. It can be seen that by continuous adjusting of cutting parameters the required roughness is assured with maximum allowable tool loading.

7. Analysis of the results

By simulation the efficiency and stability of the SDNRP with different requirements of the surface quality are tested.

The criterion for efficiency of the system is the difference between the desired and simulated R_a . The starting cutting parameters and the desired R_a are the input data. In Table 2 the requirements and the results of simulations are indicated. 10 simulations have been carried out.

The simulation results (Table 2) confirm that the SDNRP is efficient in the control of the tool loading and surface roughness. It is efficient in fine machining; this is particularly favourable, since it is intended for the operations of end milling with shank end mills, where the requirements for the quality of machining are strict.

In machining, where the roughness exceeds $1.1\mu\text{m}$, the responsiveness of the system is slowed down. Its sensitiveness for reaching the desired roughness is reduced.

Figure 12 shows the progress of the maximum cutting force without the use of the SDNRP. In this case the roughness has a random trend (Figure 14). The dynamic component of the cutting force is simulated by the block diagram in Figure 9.

The simulation graphs show that on the basis of the signals of maximum cutting force the quality of surface can be supposed. Both values are mutually related and have identical trends. The SDNRP assures constant roughness throughout machining.

The simulations confirm that the proposed system is efficient for assuring the required roughness and maintaining the constant machine loading. The control system responds to the rise of the cutting force by immediate reduction of feeding; as a result, the cutting force drops to the reference value level (Figure 13).

Constant cutting loadings lead to better quality of surface and prevent undesirable vibrations and deflections of the cutting tool. Improvement of the surface quality is most obvious in machining of corners, pockets, slots and curved surfaces, where the system prevents undesirable milling cutter deflections by reduction of feeding.

The system deals with fast changes of the cutting circumstances slightly worse due to its complex structure and errors in modeling. The reason for slow responsiveness and inaccuracy must be traced also to the manner of development of the simulation model of the feeding servo-system.

The SDNRP simulator incorporates the model of the feeding servo-system which functions according to the simplified transfer function. The latter is mathematically derived on the basis of the maker's specifications [15]. By experimental capturing of the dynamics of the feeding servo-system it is possible to improve considerably the responsiveness of the system.

8. Conclusions

The paper presents the model based system of dynamic adjusting of cutting parameters. By dynamic adaptation of feeding and spindle speed the system controls the surface roughness and the cutting forces on the milling cutter.

Table 2.
Simulation experimental results

Sim no.:	Desired surface roughness R_a [μm]	Initial cutting conditions before simulation [13,14]			Servo drive system after 15s			Produced surface finish R_a [μm]
		F_d [N]	f_c [mm/min]	n_c [min^{-1}]	F [N]	f_a [mm/min]	n_a [min^{-1}]	
1	0.38	161.4	357.12	1974	166.5	264.92	2443	0.50
2	0.51	166.67	379.98	1895	169.9	282.19	2356	0.58
3	0.64	172.1	414.53	1704	173.0	297.94	2272	0.66
4	0.76	176.8	435.26	1563	175.9	313.94	2189	0.74
5	0.81	178.5	430.41	1571	177.7	324.61	2134	0.79
6	0.89	180.9	462.19	1437	178.6	329.95	2108	0.81
7	1.02	184.7	485.14	1377	181.6	350.52	2007	0.91
8	1.14	188.1	507.75	1270	183.9	355.60	1925	0.99
9	1.27	191.2	539.24	1116	185.7	381.25	1880	1.05
10	1.52	196.8	592.58	825	195.2	411.99	1716	1.18

The correlation between the surface roughness and the cutting forces is determined by the GP method. By simulations the adequacy and stability of the control system are confirmed. It has been proved that the surface roughness which is an important indicator of the process quality can be successfully controlled by the control of cutting forces.

By maintaining constant cutting force constant quality of surface finish is assured. On the basis of results of numerous simulations it has been decided to realize experimentally the described system of control.

The system has been conceived for the end milling operation, although it can be modified for all process of machining by cutting. It eliminates the problems related to assurance of quality of machining, efficiency of machining and prevention of tool damages.

References

- [1] U. Zuperl, F. Cus and M. Milfelner, Fuzzy control strategy for an adaptive force control in end-milling, *Journal of Materials Processing Technology* 164-165 (2005) 1472-1478.
- [2] J. Kopac, M. Sokovic, Cutting properties of the PVD and CVD coatings on the ceramic substrates, *Journal of Achievements in Materials and Manufacturing Engineering* 18 (2006) 278-285.
- [3] F. Cus, U. Zuperl, E. Kiker and M. Milfelner, Adaptive controller design for feedrate maximization of machining process, *Journal of Achievements in Materials and Manufacturing Engineering* 17 (2006) 237-240.
- [4] C. Chen, M. Zhibin, An intelligent approach to non-constant feed rate determination for high-performance 2D CNC milling, *International Journal of Manufacturing Technology and Management* 9 (2007) 219-236.
- [5] G. Stute, F.R. Goetz, Adaptive Control System for Variable Gain in ACC Systems, *Proceedings of the Sixteenth International Machine Tool Design and Research Conference*, Manchester England, 1975, 117-121.
- [6] M. Tomizuka, J.H. Oh, D.A. Dornfeld, Model Reference Adaptive Control of the Milling Process, *Proceedings of the Symposium on Manufacturing on Manufacturing Process and Robotic Systems*, New York, 1983, 55-63.
- [7] S.J. Huang, C.C. Lin, A self-organising fuzzy logic controller for a coordinate machine, *International Journal of Advanced Manufacturing Technology* 19 (2007) 736-742.
- [8] W. Grzesik, J. Rech and T. Wanat, Surface integrity of hardened steel parts in hybrid machining operations, *Journal of Achievements in Materials and Manufacturing Engineering* 18 (2006) 367-370.
- [9] S. Zhang, A. Xing, L. Jianfeng and F. Xiuli, Failure analysis on clamping bolt of milling cutter for high-speed machining, *International Journal of Machining and Machinability of Materials* 1 (2006) 343-353.
- [10] J. Kopac, Influence of high speed cutting on the structure of machined high speed steel material, *Proceedings of the 11th International Scientific Conference "Contemporary Achievements in Mechanics, Manufacturing and Materials Science"*, CAM3S'2005, Gliwice – Zakopane, 2005, (CD-ROM).
- [11] L.A. Dobrzański, K. Gołombek, J. Kopac and M. Sokovic, Effect of depositing the hard surface coatings on properties of the selected cemented carbides and tool cermets, *Journal of Materials Processing Technology* 157-158 (2004) 04-311.
- [12] J. Balic, Optimization of cutting process by GA approach, *Robotics and Computer-Integrated Manufacturing* 19 (2003) 113-121.
- [13] M. Sokovic, M. Cedilnik and J. Kopac, Use of 3D-scanning and reverse engineering by manufacturing of complex shapes, *Proceedings of the 13th Scientific International Conference "Achievements in Mechanical and Materials Engineering"*, AMME'2005, Gliwice – Wisła, 2005, 601-604.
- [14] E.C. Lee, C.Y. Nian, Y.S. Tarn, Design of a materials processing technologies, *Archives of Materials Science and Engineering* 28/1 (2007) 48-56.
- [15] F. Cus, U. Zuperl, Model Reference Adaptive Force and Surface Roughness Control in Milling, *Journal of Achievements in Materials and Manufacturing Engineering* 18 (2006) 237-240.