

Concurrent engineering and DFMA approaches on the development of automotive panels and doors

F.Z. Krumenauer^{a,*}, C.T. Matayoshi^a, I.B. da Silva^b, M.S. Filho^b, G.F. Batalha^b

^a General Motors do Brasil Ltda – Automotive Body Assembly Plant, Sao Caetano do Sul, SP, Brazil

^b Department of Mechatronics and Mechanical Systems Engineering, Laboratory of Manufacturing Engineering, Escola Politecnica - University of Sao Paulo, Brazil

* Corresponding author: E-mail address: fabio.krumenauer@gm.com

Received 16.10.2008; published in revised form 01.12.2008

Manufacturing and processing

ABSTRACT

Purpose: The automotive industry, in countries such as Brazil, China and India, in contrast to the North American and European markets, is in full expansion. Due to the huge competition in the globalized automotive market, such countries face a challenge to continue this expansion. Especially important in order to win this battle, will be their capacities to release new products in the market faster than their competitors and with more cost efficiency, making an appropriate use of tools such as total quality management, concurrent engineering and increasing the use of innovative concepts in production and logistics [1,2].

Design/methodology/approach: According with the expose above, the aim of this work was to develop DFMA tools for an industrial real case. There several tools that could be included in the Design for Excellence (DFX) methodologies. Initially, two of those can be outstand here: Design For Manufacturing (DFM) and Design For Asse.

Findings: In terms of the press shop facilities of the plant the main results, were: layout optimization, press line automation feasibility, reduced setup and increased productivity, improved racks logistic, reduced overhead, reduced stamped part scraps and resources with mechanical presses selling. In terms of the planning activities, the main results were: reduce time to market, reduce press shop machinery and die stamping investments and reduce indirect cost.

Practical implications: The main proposal of concurrent engineering is to shorten a product development time through a simultaneous time implementation of the several stages of the engineering activity in parallel and under a concurrent mode offering all information required by all elements of the product life cycle.

Originality/value: This paper reviews fundamental concepts in concurrent engineering and DFX aiming to discuss criteria of assembly and manufacturability regarding the development of automotive panels and doors. A more detailed presentation of the Finite Element Analysis (FEA) and Computer Aided Design (CAD) results obtained during the practical industrial case of auto body panel development are not presented here due to data confidentiality and page limitation.

Keywords: Concurrent engineering; Sheet metal forming; BIW; DFMA; DFX; DFR; DFE

1. Introduction

The automotive industry, in countries such as Brazil, China and India, in contrast to the North American and European markets, is in full expansion. Due to the huge competition in the globalized automotive market, such countries face a challenge to continue this expansion. Especially important in order to win this battle, will be their capacities to release new products in the market faster than their competitors and with more cost efficiency, making an appropriate use of tools such as total quality management, concurrent engineering and increasing the use of innovative concepts in production and logistics [1,2]. Here the first innovative approach is to modify the information flow during the product design and manufacturing process, leaving the traditional flow showed on Fig. 1a towards a concurrent engineering approach (Fig. 1b). Following the changes that have being occurring in Brazil, the plants of car makers and suppliers, also have to adapt to

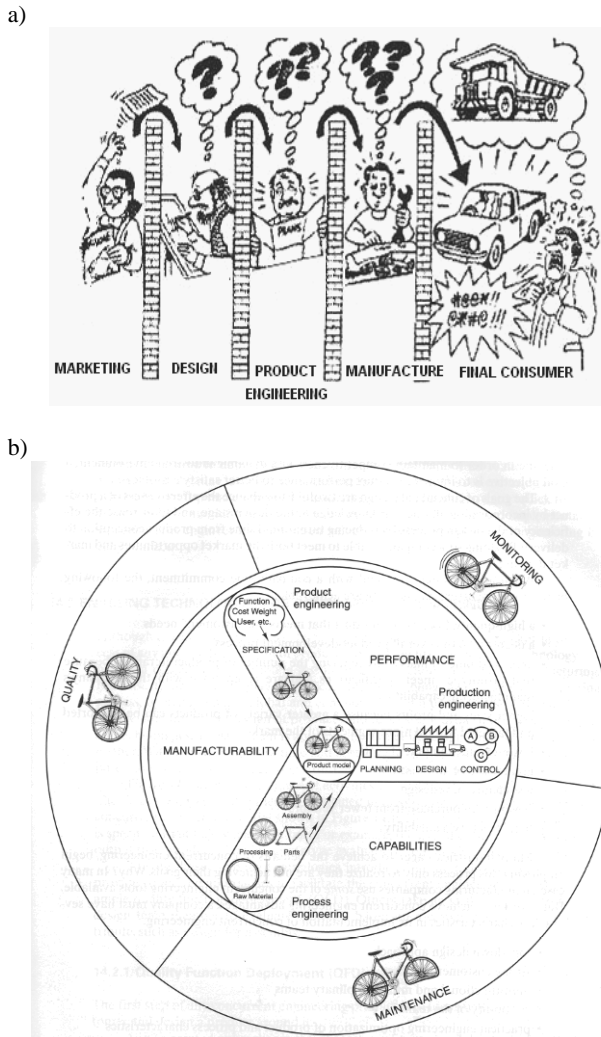

Fig. 1. Information flow in engineering design and manufacture; a) conventional flow; b) concurrent engineering approach [10]

this new context. In the case of stamped steel's sheet metal components, i.e. a metal forming project development, the time to complete the tooling is long and spread over the whole scheduled development cycle for releasing a new vehicle [3,4]. So, concurrent engineering concepts applied for stamped parts become extremely important to attain the goals required for the project. Among the initiatives of concurrent engineering, the approaches and tools of Design For Manufacturing (DFM) are highlighted here in terms of a practical development process of side panels and doors of an automotive body-in-white (BIW) example [5,6].

2. Concurrent engineering

The main proposal of concurrent engineering is to shorten a product development time through a simultaneous time implementation of the several stages of the engineering activity in parallel and under a concurrent mode offering all information required by all elements of the product life cycle. Studies show that the design approaches affects the final cost of a new product more than any other factor. Fig. 2 compares two traditional cost curves; one shows the influence on cost of a change in the project during the design phase and other shows the influence of these changes during the same period. Surveys show that, based on a traditional accounting, however, the cost of Design for a new car represents approximately 5% of the total; it is responsible for 70% of the product cost, while the material, direct and indirect costs represent 30% of the cost (as shown in Fig. 3). From the manufacturing perspective, less than 30% of the product cost may be affected by improvements initiatives, starting from the point at which the product is already defined. So design have enormous influence in terms of power to compete on quality and cost. [7,4,8,9]. According with the expose above, the aim of this work was to develop DFMA tools for an industrial real case.

3. DFMA and DFX tools for concurrent engineering

There several tools that could be included in the Design for Excellence (DFX) methodologies. Initially, two of those can be outstand here: Design For Manufacturing (DFM) and Design For Assembly (DFA).

3.1. DFMA – Design for Manufacturing / Assembly

The core of any system of Design for Manufacturing (DFM) or Design for Assembly (DFA) is a set of rules to be followed aiming at design efficiency in terms of its manufacturing engineering. Fig. 4, show two examples originally proposed by [7].

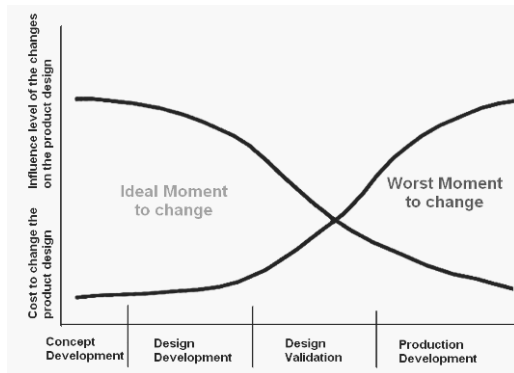

Fig. 2. Relative importance of development steps on the final product cost [7]

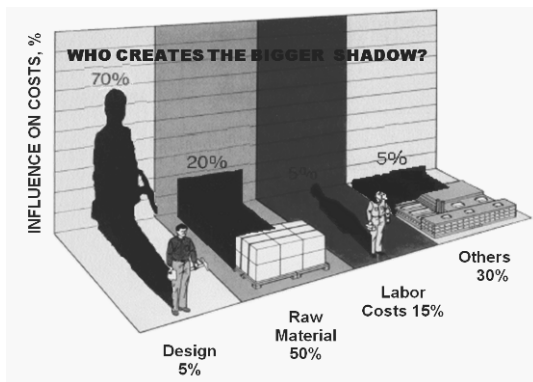

Fig. 3. Costs influence lever and the design [7]

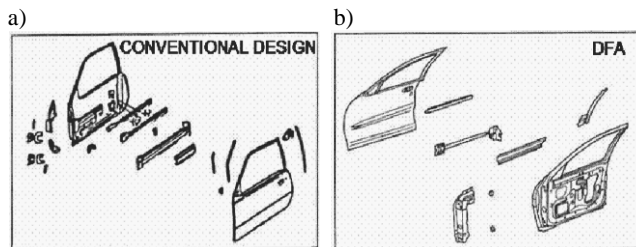

Fig. 4. Automotive door component sets: a) conventional, b) DFA

3.2. DFM

DFM (Design for Manufacturability) is a set of methods and tools that support concurrent engineering and that can be understood as an analytical process structure of concurrent engineering tools that provide conditions to design a product regarding its manufacturability. Through the use of the DFM concepts, designers and engineers can attain main target: to satisfy the customer's requirements in terms of functionality, performance, style and quality at low cost.

Each DFM tool focuses on a manufacture specialty or on a manufacture processes family. DFM-Assembly (DFA or Design

for Assembly) is indicated to product architecture and assembly. Other DFM tools (for instance, DFM – Sheet Metal Forming, DFM – Injection Moulding, DFM - Machining) are indicated to part fabrication. Engineers can use those DFM variants for high or low volume, simple or complex and bigger or smaller products. DFM benefits are:

- Simpler fabrication and assembly;
- Improved ergonomics;
- Reduced rework;
- Reduced mass;
- Improved serviceability;
- Better quality;
- Reduced logistic time;
- Reduced time to market launching;
- Less production problems;
- Reduced program budget.

3.3. DFA

DFA (Design for Assembly) is a DFM specialty; it is a structured method to improve product components assembling. Both, DFM and DFA are essentials applications during product design and are also called DFMA (Design for Manufacturing and Assembly). The following criteria are considered in a DFA study:

- Reduce and optimize part counts and types.
- Utilize optimum attachment methods.
- Use layered assembly approach. Let gravity help.
- Minimize reorientations during assembly.
- Eliminate the need for adjustments.
- Design parts so that they are easy to self-align and locate.
- Ensure adequate access and unrestricted vision.
- Ensure ease and safety of part and assembly handling.
- Design parts that can only be installed correctly.
- Minimize the number of tools required.

See an example of DFA approaches on the Figure 5.

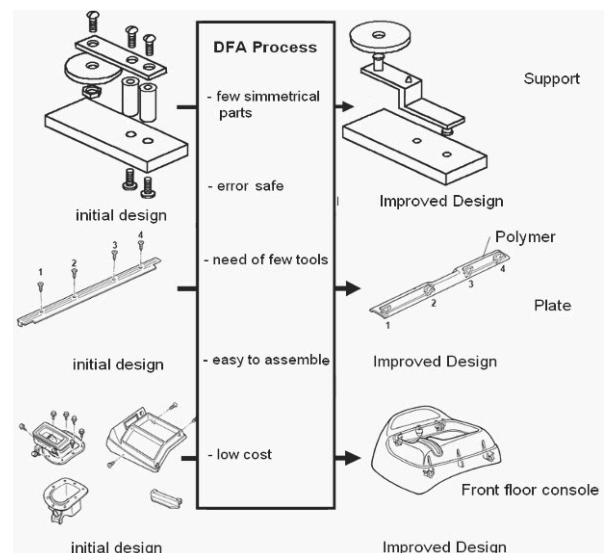

Fig. 5. Design improvements by the DFA process

3.4.DFX – Design for X on the product development

Conceptual concurrent engineering tools as DFR (Design for Recycling), DFE (Design for Environment), DFD (Design for Disassembly), etc, are contemplated in DFX (Design for Excellence) (Fig. 6). The Design for X is a generic term for all types of concurrent engineering tools which are oriented to consider environment, recycling, disassembly, life cycle, among other requirements [11, 12, 13, 14].

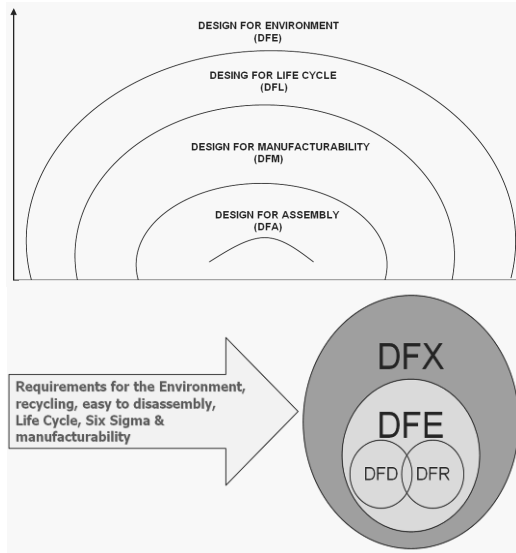

Fig. 6. Scope of the Methodologies known as Design For Excellence (DFX); Design For Environment (DFE); Design For Recycling (DFR) and Design For Disassembly (DFD) [15]

3.5.DFE – Design for Environment and LCA –Life Cycle Analysis

Design for Environment (DFE) considers all environment aspects in each phase of the product development process. It is focused on reducing as much as possible the environmental impact of this product during its life cycle, since from its manufacture just to its disposal (Figure 7). This will only be possible, linking the analysis of the life cycle (LCA) with the engineers' and designers' professional experience [9, 12,16,17].

According to Hockerts et al., [16], from DFE tools are expected to:

- Provide meaningful results based on simplified LCI (life data and product descriptions);
- Be user-friendly and not require special LCA expertise from users (designer, R&D or marketing);
- Provide means for environmental exchange between members of an organization;
- Be adaptable to each individual company's need to assure the free choice of each company's policy in terms of database, and end- result indicators;
- Produce design and end-of-life indicators.

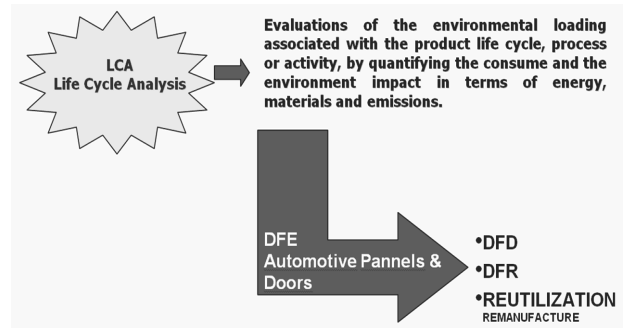

Fig. 7. Relationship between DFE and LCA for automotive panels

Addouche, [17], presents a series of questions and answers about DFE to provide better understanding of this concept (see Fig. 8).

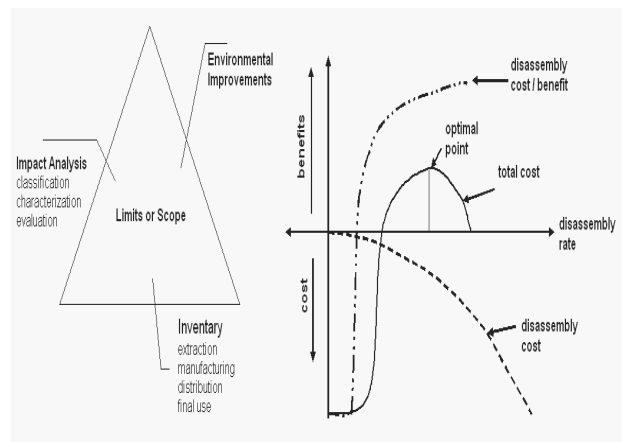

Fig. 8. Cost and benefits for a DFD approach [17]

Why using DFE?

The advantages are:

- Cost reduction;
- Product improvement;
- Pressure reduction from governmental laws ;
- Trademark image improvement;
- Environmental performance improvement.

How to apply DFE?

The design integration varies according to each company and it is basically applied in four main items:

- Investigation (according to the right directions);
- Promotion (according to the company policy);
- Follow-up of the integration process (reports and gratuities);
- Information feedback.

Three main activities resulting from DFE methodologies and that directly refer to product valorization at its life cycle end:

- Design for Disassembly - DFD;
- Design for Recyclability - DFR;
- Design for Remanufacturing.

- Activities whose main attributions are:
 - The valorization rate improvement, facilitating the product components and raw material recovery;
 - Material recycling capability improved;
 - Components reuse to reduce the waste of the natural resources.

3.6.DFD

According to Desai & Mital, [18], in the engineering context, disassembly may be defined as the organized process of taking apart a systematically assembled product (assembly of components). Products may be disassembled to enable maintenance, enhance serviceability and/or to affect end-of-life (EOL) objectives such as product reuse, remanufacture and recycling. Then, the design for disassembly is necessary condition for products to be economically recycled, by improving components and material reuse and remanufacture processes, extending the service life of the products and components. The maintenance can be simpler and the output of all these improvements mean less raw material and energy waste and better performance in terms of life cycle of evaluation. Benefits from using DFD are:

- “Core business components” can be recovered;
- Metals separation with no contamination, improving process quality;
- Dismountable non-metallic parts can be re-processed.

Examples of vehicles dismantling lines - Car Recycling System (CRS) - can be found in Europe, USA and Japan [11,12]. An analogy of an assembly line plant can be made, however dedicated to disassembly. Vehicles are carried continuously in cradles/skids and, sequentially, parts of its structure (autobody, transmission, engines, cockpit, etc) are dismantled and separated until only the body structure component remains. (See Figure 9).

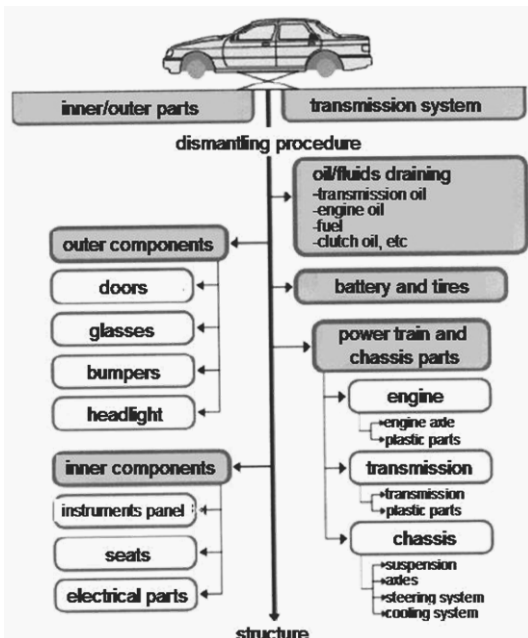

Fig. 9. Typical vehicle dismantling line [20]

3.7. DFR

DFR success depends on the good DFD output. DFD and DFR are closely related, because they are part of DFE methodology and should be applied together during design product development. DFR focuses on the recyclability, maximum disassembly rate and product end-of-life treatment.

3.8.DFM application to auto body panels

This case will be about the application of DFM in a specific sheet metal part designed for product and manufacturing engineering from a multinational automaker that has been manufacturing stamped parts in Brazil for decades. Until late 1980s, any size and type of metallic parts was fabricated at the press shop of this company. One of the strategies adopted in the early 1990s was to be focused only on the main stamped parts, like doors, side panel, hood, fender, etc. Small parts and not “core business”, small inner parts for instance, were outsourced. The main results were reduction of structural press shop cost due to the disposal of smaller presses (“C” type and progressive presses) and labour costs. Nowadays, the press shops only have a mechanical presses line, each with its die stamping. The stamped sheet metal part manufacturability criteria must be established before starting its design, because it will be the standard and give support to design areas (see the following maximum panel drawn in depth and blank size criteria examples and a DFMA improvement of an automotive door development). For these cases, the DFMA methodology is illustrated in Figure 10 to 18. [5,6].

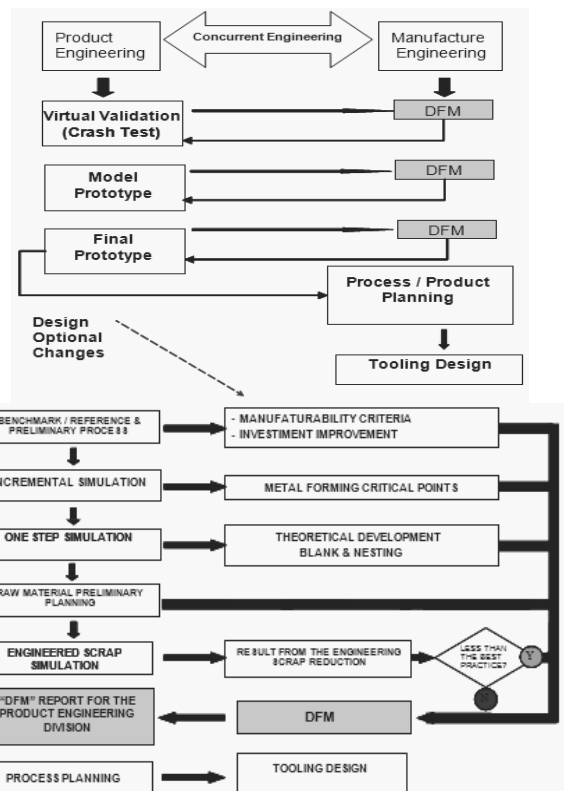

Fig. 10. DFM information flow on the development of BIW panels

The DFM approach was based on some previous definitions: the Panel draw depth is the greatest depth of the panel in an elevation view in die position. It does not analyze flanges because they are drawn out flat in the draw die normal on the surface which the flange bends off from (Figures 11 and 12).

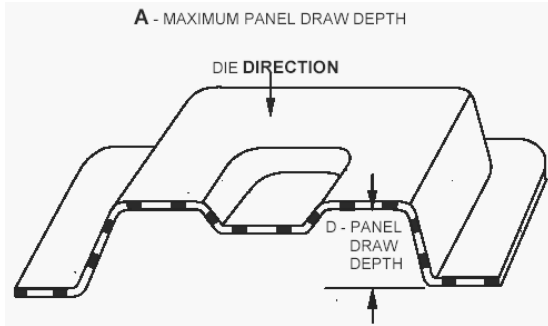

Fig. 11. Panel draw depth

The purpose of this analysis was to evaluate the blank dimension and check if neither sheet metal part are over estimated nor under estimated for the presses line [5]. For door and closure developments. See Krumenauer et. al. and Koehr [6,19].

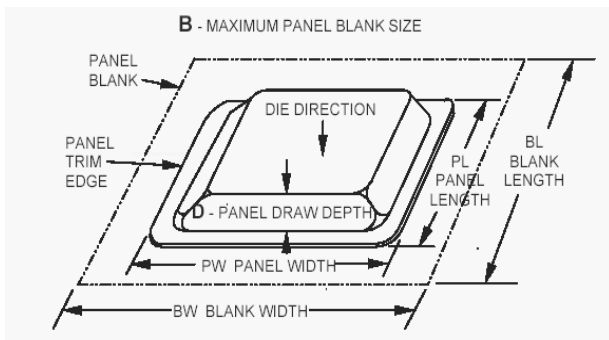

Fig. 12. Blank dimensioning estimation

- If the panel depth is deeper than the press size:
 - Manufacturing costs increase due to the need of a double action press resulting in a reduction of throughput;
 - Investment costs increase due to the need of a panel turnover;
 - Part quality decreases and manufacturing scrap increase due to down dings caused by dirt in the lower die cavity;
- If the panel size is larger than the press size:
 - Manufacturing costs increase due to requiring a larger press size, resulting in a reduction of throughput.

This standard makes sense since if applied in the beginning of the part design, through workshops, among design area, product and manufacturing engineering areas. In this phase, the vehicle model is clay type and discussion is just about body style. After style freeze, product and manufacturing engineering will work together to define the inner part of the body. At this stage, the manufacturing criteria are well applied, because referring parts do not affect the vehicle body style.

Besides the manufacturability criteria standards, other tools are essential for the DFM promotion in these phases of the project, as mentioned below:

- CAE (Computer Aided Engineering) - finite elements software: useful to estimate the sheet metal forming flow (mainly in the drawing operation), blank size and blank nesting. By using it, the following outputs can be achieved [4].
 - Stamped part geometry and sheet metal forming evolution;
 - Width sheet metal distribution;
 - Equivalent plastic forming;
 - Material flow;
 - Blank holder and female die stamping force;
 - Failure (tearing and wrinkle).

The finite-element method (FEM) is effective in analyzing general structural problems. In sheet metal forming practice, two main finite element approaches have been used: one-step and incremental. One-step is more useful if not so accurate output requirements are needed just after and before the frozen car style phase, see [4]. In a typical one-step solver, the final part geometry and boundary conditions are known and are used to predict blank geometry and size, thickness, strain and stress distribution and springback prediction [3].

Engineered scrap has been used to provide a relation between blank size dimension and the stamped part. These data are based on similar previous parts produced and benchmarking, all from a CAD system.

- CAD (Computer Aided Design): is an essential tool for promoting concurrent engineering, because of the time saving to analyze the part characteristics and engineered scrap (Fig. 13).

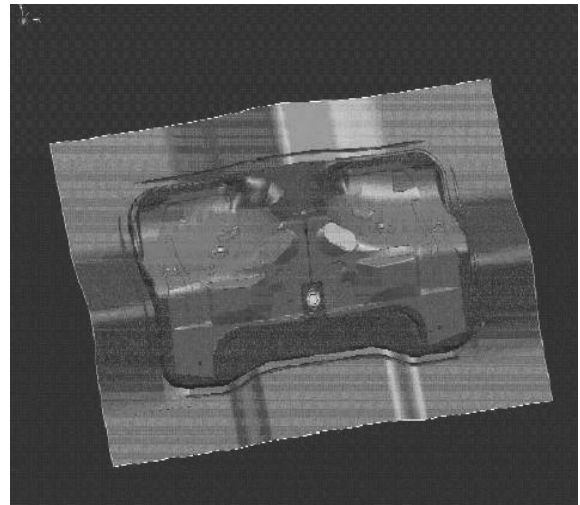

Fig. 13. CAD example

As an example, the application of DFM to inner side panel will be described. Initially, the process planning was based on the following stamped panel blank size and shape (Figure 14):

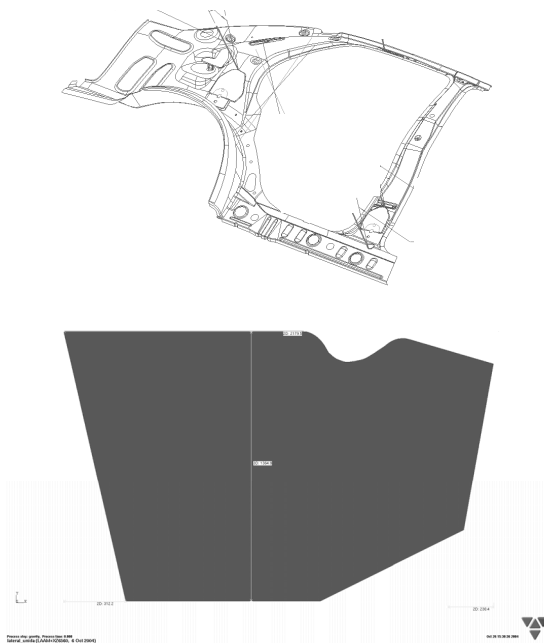

Fig. 14. Preliminary part and blank

After product and manufacture workshops, a definition was established in terms of part processing and blank size and shape, as in Figure 15. Analyzing stamped parts manufacturing requirements by means of Finite Element Method (FEM) and engineered scrap, the simultaneous process of two parts was possible; the inner side panel and the outer extension side panel could be stamped using just a die set. Moreover, one operation was reduced comparing to the preliminary process planning, which means one less die stamping.

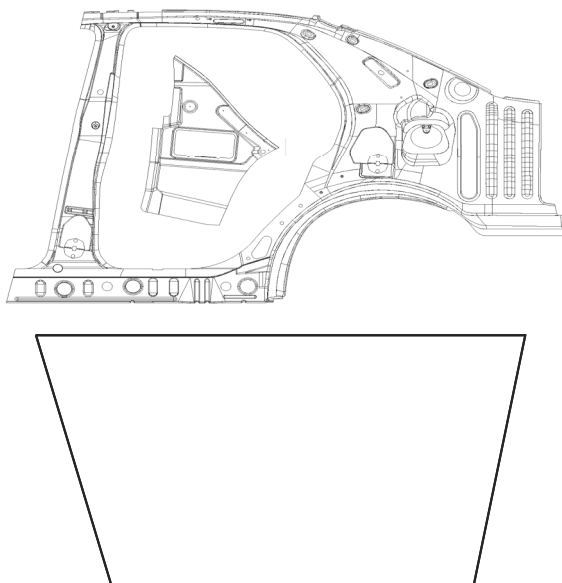

Fig. 15. Parts and blank after DFM application

The DFMA methodology sketched in Fig. 10 for the development of the side panels are summarized in Fig. 16. A second example of DFMA improvement on automotive doors is presented in Fig. 17.

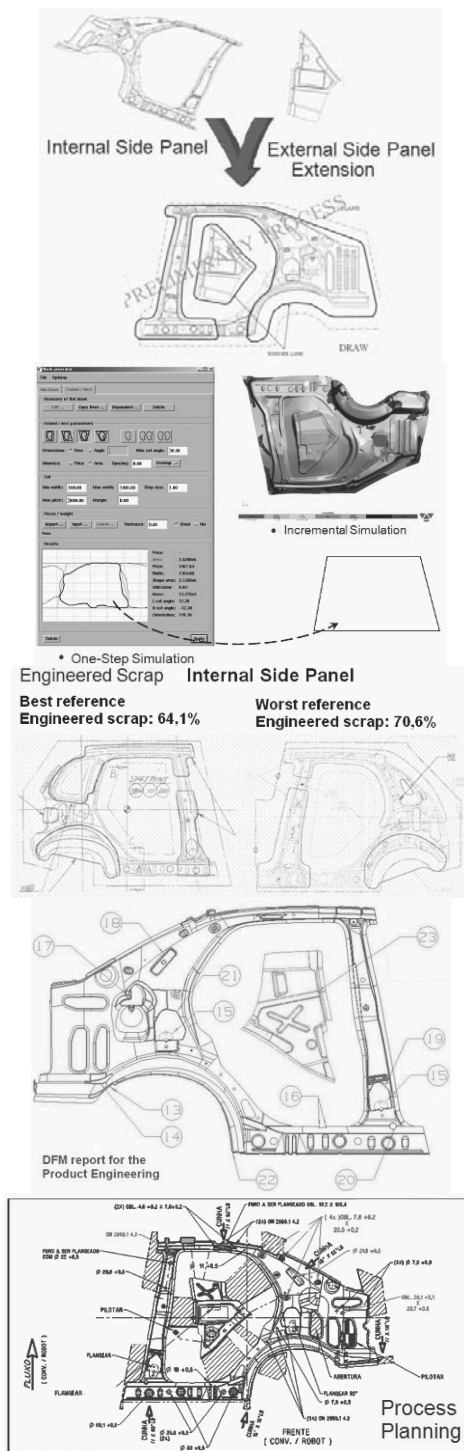

Fig. 16. Summary of the side panel DFMA approach following the information flow described in Figure 10 [5]

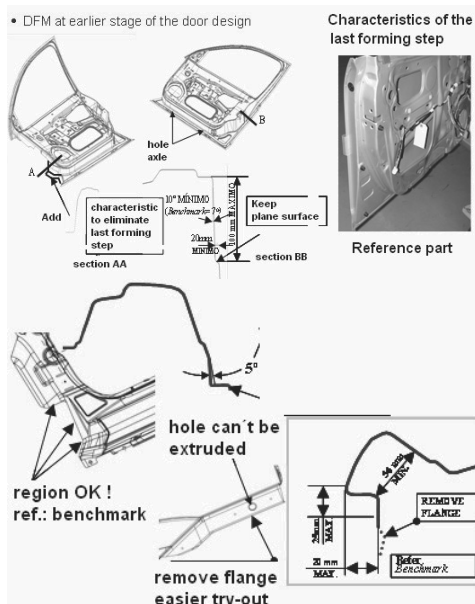

Fig. 17. Example of DFMA approach in the development of an automotive door [6]

4. Conclusions

In terms of the press shop facilities of the plant, the main results were:

- Layout optimization;
- Press line automation feasibility;
- Reduced setup and increased productivity;
- Improved racks logistic;
- Reduced overhead;
- Reduced stamped part scraps;
- Resources with mechanical presses selling.

In terms of the planning activities, the main results were:

- Reduce time to market;
- Reduce press shop machinery and die stamping investments;
- Reduce indirect cost.

Meeting manufacture criteria, not only anticipated the manufacturing engineering autobody design activities reducing the time to market, but reduces investments and structural cost of the plant. These strategies have generated resources with the mechanical presses selling and create a new platform with fewer operations, on average, comparing similar parts with previous designs. The use of DFX in terms of the product life cycle analysis concerning environmental requirements is not really applied in sheet metal parts and their assembly in the autobody design in Brazil, as in the DFE, DFD and DFR methodologies.

Basically, two external factors can promote the environmental, dismantling and recycling in the autobody parts and assembly design: a legislation that regulates this kind of subject and the client's demanding for having a car the maker of adopts environmental issues in his designs. Fig. 18 summarizes the benefits of the DFMA at the developments of automotive side panels and doors at a Brazilian plant discussed in this paper.

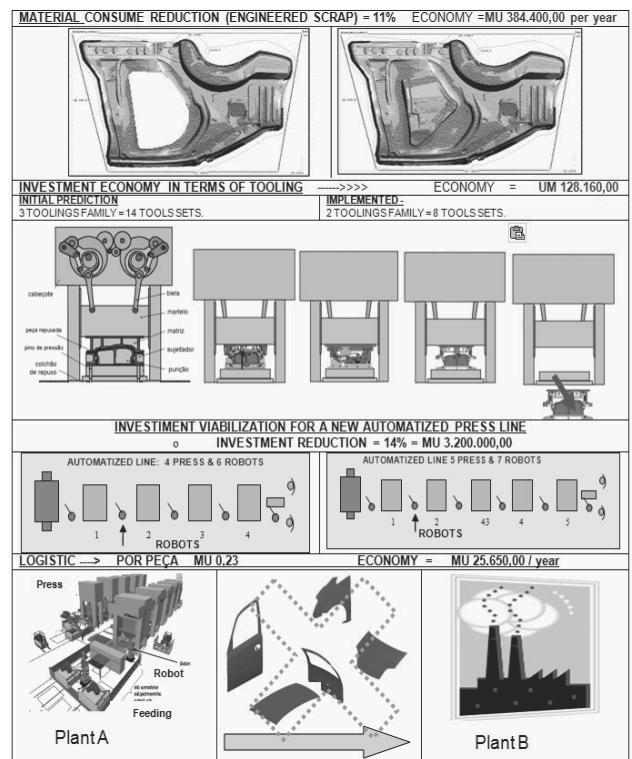

Fig. 18. Economical benefits obtained by the DFMA approach on the development of an automotive BIW side panel blank

Acknowledgements

The authors acknowledges the support provided by the General Motors plant in Brazil, at Sao Caetano do Sul, Sao Paulo – Brazil, as well as for the professional master program on automotive engineering coordinated by the Escola Politecnica of the University of Sao Paulo.

References

- [1] R.F.Z. Chiusoli, J.C. de Toledo, Engenharia simultânea: estudo de casos na indústria brasileira de autopeças, Proceedings of the Congresso Brasileiro de Gestão de Desenvolvimento de Produto, Ed. UFSCar, Brazil, 2000, 10-19.
- [2] J.R.S.T. Motta, Melhoria da qualidade do automóvel brasileiro, Brasília, Câmara dos Deputados, 2001, 5 (Nota técnica, 104036).
- [3] G.F. Batalha, R.C. Schwarzwald, G.L. Damoulis, New trends in computer simulation as integrated tool for automotive component development, Proceedings of the International Conference "Numerical Methods in Industrial Forming Processes" NUMIFORM, Columbus, 2004, 21032-21037.
- [4] G.L. Damoulis, G.F. Batalha, Desenvolvimento de processo de conformacao de chapas metálicas usando simulação computacional como ferramenta integrada no desenvolvimento de

- carrocerias automotives, Engineering and Science Journal 13 (2004) 33-39 (http://www.cieng.ufu.br/REVISTA_COBEF.PDF).
- [5] C.T. Matayoshi, Concurrent Engineering - Study of the Process Requirements and Life Cycle Influence in the Development of Automobile Stamped Parts, Master Thesis, EPUSP, Sao Paulo, 2005 (Full text available: http://www.automotiva-poliusp.org.br/mest/banc/pdf/matayoshi_cesar.pdf).
- [6] F.Z. Krumenauer, G.F. Batalha, Concurrent Engineer and Design for Manufacturing and Assembly Automotive Doors Projects, Boletim Técnico EPUSP-BT/PME/0803 (2008) 15, (<http://www.mecanica-poliusp.org.br/05pesq/cont/pdf/803.pdf> and full text of the professional master thesis available on http://www.automotiva-poliusp.org.br/mest/banc/pdf/krumenauer_fabio.pdf)
- [7] G. Boothroyd, P. Dewhurst, W. Knight, Product Design for Manufacture and Assembly, Marcel Decker Incorporation, New York, 1, 2002, 1-29.
- [8] G.L. Damoulis, E. Gomes, G.F. Batalha, Combined finite element: forming limit diagram methodology for the development of automotive body stamped parts, International Journal of Mechatronics and Manufacturing Systems 1/2-3 (2008) 264-281.
- [9] J.R. Hartley, Engenharia Simultânea: um método para reduzir prazos, melhorar a qualidade e reduzir custos. First Edition, Bookman, Porto Alegre, 1998, 266.
- [10] T.C. Chang, R. Wysk, H.P. Wang, Computer-Aided Manufacturing, ch. 14- Concurrent Engineering, Prentice Hall International Series in Industrial and Systems Engineering, Prentice Hall, Second Edition, 1998, 589-616.
- [11] M. Geiger, Towards Clean Forming Techniques, Annals of the CIRP 44/2 (1995) 581-588.
- [12] R. Kopp, A. Schmitz, Plastic working in Germany and related environmental issues, Journal of Materials Processing Technology 59 (1996) 186-198.
- [13] S. Schmidt, Preventive Optimisation of Costs and Quality for the Total Life Cycle - design for manufacture, assembly, service, environment (DFMA), Proceedings of the Conference and Exposition "Total Life Cycle", Graz, 1998, 1-9.
- [14] T.C. Kuo, S.H. Huang, H.C. Zhang, Design for manufacture and design for 'X': concepts applications and perspectives, Computer and Industrial Engineering 41 (2001) 1-20.
- [15] P.J.M. Figueiredo, S.J. Jacovelli, Projeto para montagem de máquinas-ferramentas. Máquinas e Metais, Aranda Editora XLII/488 (2006) 156-197.
- [16] K. Hockerts, S. Adda, H. Teulon, D. Dowdell, N. Kirkpatrick, S. Aumonier, Beyond Life Cycle Assessment, an Integrative Design for Environment Approach for the Automotive Industry, SAE Technical Paper Series (1998) 1-7.
- [17] S. Addouche, Contribution à une demarche de conception optimisée des processus de désassemblage, 203 f. These (Grade de docteur de l'Université de Franche-Comte), 1, 2003, 1-23.
- [18] A. Desai, A. Mital, Evaluation of disassemblability to enable design for disassembly in mass production, International Journal of Industrial Ergonomics 32 (2003) 1-17.
- [19] R. Koehr, ULSAC - Lightweight steel auto closures, Proceedings of the SAE 2001 World Congress, Detroit, 2001, SAE Paper 2001-01-0076.
- [20] G.T. Nakamura, M.T. Yokota, G.F. Batalha, Linha de desmontagem de chapas de aço para reciclagem. Monography PMR - EPUSP, Sao Paulo, 2002, 72.