

Determination of thermal diffusivity of carbon/epoxy composites with different fiber content using transient thermography

G. Wróbel ^a, Z. Rdzawski ^{b,c}, G. Muzia ^b, S. Pawlak ^{a,*}

^a Division of Metal and Polymer Materials Processing, Institute of Engineering Materials and Biomaterials, Silesian University of Technology, ul. Konarskiego 18a, 44-100 Gliwice, Poland

^b Institute of Non-Ferrous Metals, ul. Sowińskiego 5, 44-101 Gliwice, Poland

^c Division of Materials Processing Technology, Management and Computer Techniques in Materials Science, Institute of Engineering Materials and Biomaterials, Silesian University of Technology, ul. Konarskiego 18a, 44-100 Gliwice, Poland

* Corresponding author: E-mail address: sebastian.pawlak@polsl.pl

Received 17.09.2009; published in revised form 01.12.2009

Properties

ABSTRACT

Purpose: The purpose of present study was to determine the thermal diffusivity of carbon fibre/epoxy composites with different fibre content using flash method.

Design/methodology/approach: The experiments have been performed using transient thermography to obtain the thermograms for carbon/epoxy specimens with different carbon fibre content. From recorded thermograms the thermal diffusivity values were determined for two different heating conditions to verify the effect of heating conditions on thermal diffusivity values.

Findings: It was found from obtained results that composites with different carbon fibre content had different values of thermal diffusivity. The method initially proposed by Parker as “flash method” for the thermal diffusivity measurements of homogeneous solids was successfully applied to determine thermal diffusivity of CFRP composites. Relationship showed that the thermal diffusivity is linear function of carbon content in considered materials.

Research limitations/implications: Developed relationships between thermal diffusivity and fibre content is not universal for any other carbon fibre reinforced composites (manufactured using different technique and/or using different constituent materials), so different relationships should be determined for different composites.

Practical implications: The results obtained from present experiment would be of great importance in the industrial or laboratory applications to determine thermal diffusivity in carbon fibre reinforced composite materials.

Originality/value: The originality of present investigation is in application of transient thermography based on flash method approach to measure thermal diffusivity of carbon/epoxy composites.

Keywords: Non-destructive testing; Transient thermography; Thermal diffusivity; Carbon fibre content

Reference to this paper should be given in the following way:

G. Wróbel, Z. Rdzawski, G. Muzia, S. Pawlak, Determination of thermal diffusivity of carbon/epoxy composites with different fiber content using transient thermography, Journal of Achievements in Materials and Manufacturing Engineering 37/2 (2009) 518-525.

1. Introduction

There are many examples taken from e.g. aircraft industry, non-destructive testing practice or other industrial fields where knowledge of thermal diffusivity is required. Also, engineering materials are selected considering their thermal properties like thermal conductivity which can be calculated indirectly using experimentally evaluated thermal diffusivity by transient method and with additional knowledge of specific heat and density of a material (according to Eq. 1, presented below). This approach has often been proposed because the thermal diffusivity measurements are usually less time consuming than stationary techniques used for thermal conductivity measurements [1]. Moreover, the stationary techniques used for thermal conductivity examinations require a heat flux measurement which is long and difficult to control giving not accurate results [1]. The most popular transient method which has been extensively used to measure thermal diffusivity of homogeneous materials is “flash diffusivity method” [2]. The first measurements were reported by Parker et al. in 1961 [3] who successfully applied the flash method, which in general, consist of heating the front surface of a specimen by short thermal pulse, recording and then analyzing the temperature response on the rear surface. The method was later modified by other researchers and recently, several authors have used flash method in many different cases [4-6].

In the present study, authors applied flash method to measure thermal diffusivity of carbon/epoxy composites with different carbon fibre content using transient thermography.

Transient thermography as a non-destructive testing (NDT) technique was until recently considered as an emerging technology [7] and nowadays is widely used in characterization of composite materials [8]. The use of infrared (IR) thermography is recommended whenever a fast inspection method, involving no contact with tested part is required. It is also known that IR thermography is able to detect defects and anomalies in many engineering materials. In the case of polymer composite materials, it is applicable to the detection of cracks, impact damages and fatigue degradation [9,10].

Previously, the authors used transient thermography for the fiber content examination in carbon/epoxy composites, correlating the carbon content with chosen parameters determined from obtained thermograms [11] without considering the thermal diffusivity of material. The technique was successful only in the case of composites with the same wall thickness, but in the case where composite has differences in thickness, the determination of thermal diffusivity is required [12].

Nowadays, the modern polymer composite materials are subject of many different research considerations [13-15] and also many works deal with the effect of fiber content on chosen characteristics of composites [16,17], but at the same time no information can be found concerning the effect of fiber content on thermal diffusivity in carbon/epoxy composite materials.

2. Principle of the method

Thermo-physical properties, including thermal conductivity, thermal diffusivity and specific heat are the free most important

properties of material that are needed for heat transfer calculations. The Equation that relates these properties is given by

$$\alpha = \lambda / \rho c_p \quad (1)$$

where:

α – thermal diffusivity [m^2/s],
 λ – thermal conductivity [W/mK],
 ρ – density [g/cm^3],
 c_p – specific heat [J/kgK].

The thermal diffusivity can be used as an indicator of how quickly a material will change temperature in response to the application of heat [4].

Parker et al. [3] in 1961 proposed the heat pulse method or “flash diffusivity method” to measure the thermal diffusivity of homogeneous materials. In this technique, a uniform heat pulse Q of short duration compared to the transient time through a material is incident on the front surface of specimen and temperature rise on the rear surface is recorded. If the heat losses are neglected, the temperature of rear surface is given by [3,4]:

$$U(L,t) = 1 + 2 \sum_{n=1}^{\infty} (-1)^n \exp(-n^2 \omega) \quad (2)$$

where:

$$\omega = \pi^2 \alpha t / L^2 \quad (3)$$

and $U(L,t)$ are dimensionless parameters, n is an integer, L –specimen thickness, and

$$U(L,t) = \Delta T(L,t) / \Delta T_M \quad (4)$$

where: $\Delta T(L,t)$ is the temperature above ambient at the time t and ΔT_M is the maximum temperature rise.

Equation (2) is plotted in Fig. 1. [4].

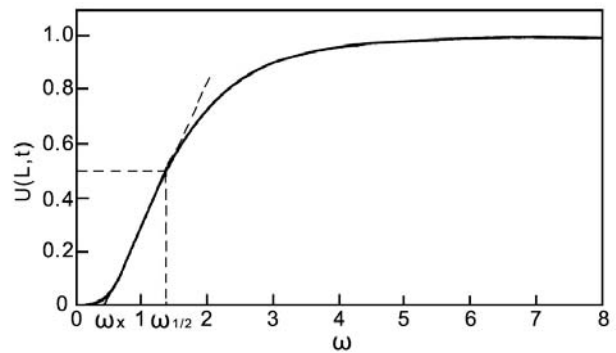

Fig. 1. Dimensionless temperature history on the rear surface [4]

Parker et al. [3] suggested to determine the thermal diffusivity α from Eq. (2) and Fig. 1 at half the maximum temperature rise ($U = 0.5$), $\omega = 1.37$ and the thermal diffusivity can be calculated using Equation [3,4]

$$\alpha = 1.38L^2 / \pi^2 t_{0.5} \quad (5)$$

where, $t_{0.5}$ is the time taken to reach half maximum temperature.

The standard [18] also suggest to verify the conformity of results by taking into consideration other points from normalized temperature history plots (e.g. $U = 0.3$) and then $\omega = 0.99$ [18].

It is not necessary to know the amount of energy absorbed in the front surface in order to determine the thermal diffusivity [3].

3. Experimental

3.1. Methodology

Transient thermography was applied to evaluate the thermal diffusivity values from carbon/epoxy specimens with different fiber content. The method consists in the heating of front surface of specimen using short uniform heat pulse and measuring the temperature evaluation on the rear surface. The thermal diffusivity values were obtained from temperature – time plots (thermograms) using Parker's method [3] for $U = 0.5$ and according to standard [18] for $U = 0.3$.

3.2. Materials

The materials used in the experiment were made of plain weave carbon fabric ("Sigratex", "SGL Carbon Group", Germany), epoxy resin („Epidian 53", "Organika-Sarzyna", Poland). Selected details about constituent materials are shown in Table 1.

Table 1.
The properties of constituent materials

Parameter	Carbon fibre (* fabric)	Epoxy resin
Density	1.70 [g/cm ³]	1.13 [g/cm ³]
Areal weight	240 [g/m ²]*	-
Thermal conductivity coef.	~15.0 [W/mK]	~0.22 [W/mK]

Carbon fiber reinforced epoxy composites were fabricated by hand lay-up with variation of carbon content, which was obtained using different number of carbon layers with the same total thickness of the specimens. Two groups of specimens with square shape (100 by 100 mm) were prepared, including four specimens with thickness of about 4 mm and four with thickness of about 5 mm. The chosen properties of prepared specimens are shown in Table 2.

Table 2.
Properties of specimens tested

Specimen symbol	Amount of fabric layers	Thickness [mm]	Fibre content [% vol.]
C404	4	4.18	13.1
C406	6	4.32	19.0
C408	8	4.21	26.2
C409	9	4.14	29.8
C506	6	5.02	16.4
C507	7	4.84	19.9
C509	9	4.99	24.7
C510	10	4.86	28.5

The first number after letter "C" in specimens' symbols (see Table 2) indicates the approximate thickness in millimeters and second with third number - amount of fabric layers.

All specimens were painted with a thin matt black coating with an emissivity value of about 0.95 in order to eliminate reflections, effect of overhead lights or humans and to ensure homogeneity in the specimen surface emissivity.

3.3. Apparatus and measurements

To provide a high accuracy and repeatability of all measurements an automatic testing station (Fig. 2) was used. The apparatus was designed and built to provide a uniform heating conditions such as stable specimen mounting, constant distance between heating source and specimen and also precise heating time for all measurements.

Each specimen was mounted vertically (parallel to the infrared radiator) in a hole of the thermal shield. As a thermal wave source a 1200 W black-ceramic infrared radiator with surface dimensions of 250 x 62 mm and wavelength range of 2-10 μm was used.

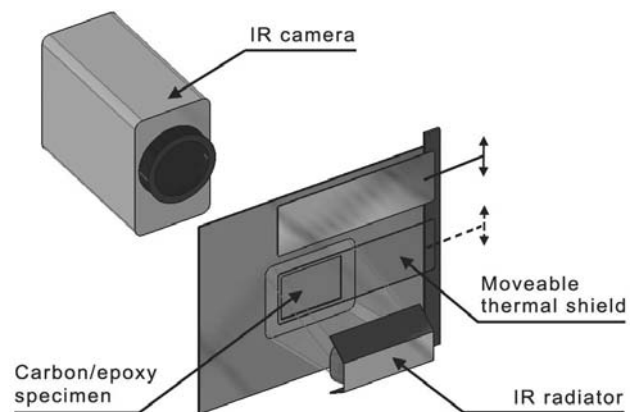

Fig. 2. Scheme of the experimental arrangement

The temperature response was recorded with IR-camera from two areas (area 1 and area 2, see Figs. 3-6) of rear surface of specimen tested to compare the obtained results.

Due to the relatively low conductivity of considered CFRP composites, in comparison with metals, a long-pulse approach was selected to ensure a linear temperature response on rear surface. The heating time of 2.0 seconds and distance between thermal wave source and specimen (Table 3) was determined experimentally when linear temperature increase was observed and large enough in comparison with temperature noise.

Table 3.
Pulse heating conditions

Condition	Specimen to radiator distance [mm]	Radiator temperature [°C]	Heating time [sec]
A	20.0	650	2.0
B	30.0	650	2.0

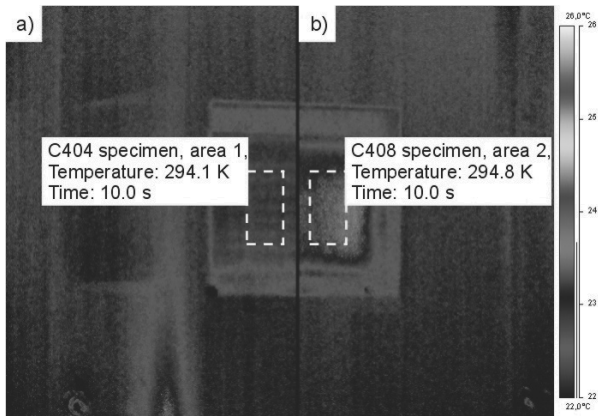

Fig. 3. Comparison of the thermal images of C404 (a) and C408 (b) specimens captured at the rear surfaces (area 1 and 2) after 10.0 seconds

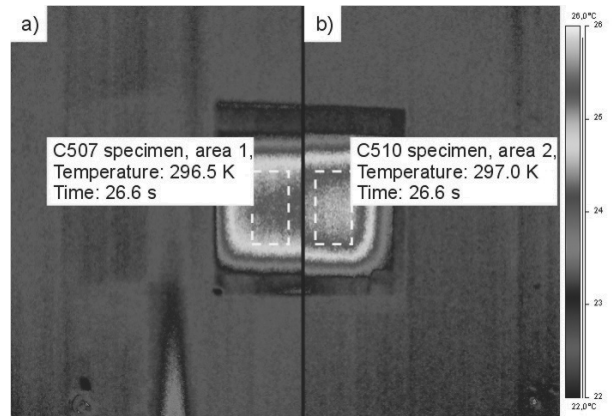

Fig. 6. Comparison of the thermal images of C507 (a) and C510 (b) specimens captured at the rear surfaces (area 1 and 2) after 26.6 seconds

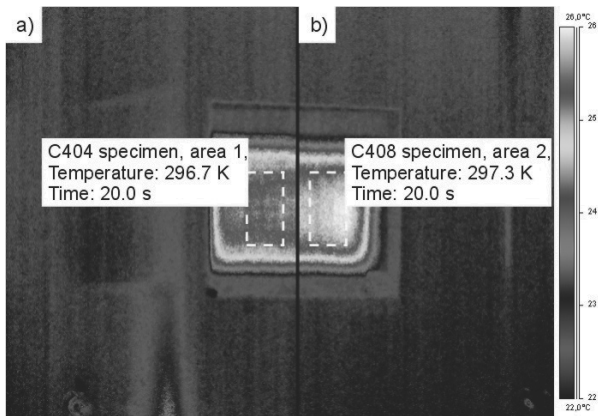

Fig. 4. Comparison of the thermal images of C404 (a) and C408 (b) specimens captured at the rear surfaces (area 1 and 2) after 20.0 seconds

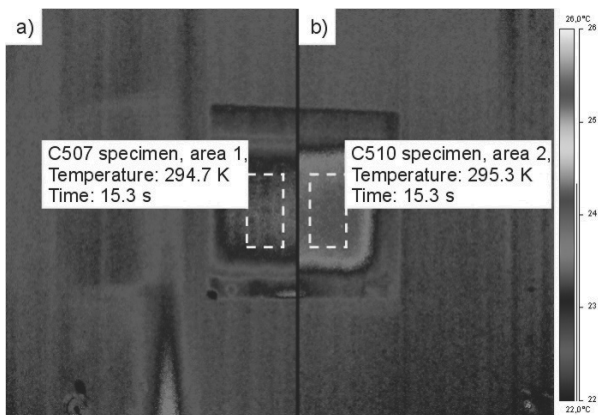

Fig. 5. Comparison of the thermal images of C507 (a) and C510 (b) specimens captured at the rear surfaces (area 1 and 2) after 15.3 seconds

The temperature variations was measured at the rate of 7.5 images per second and recorded using IR camera (“ThermaCAMTMSC640”, “Flir Systems”, Sweden) with focal plane array (FPA) detector. For thermograms’ analysis the “Researcher Professional 2.9” (“Flir Systems”) software was used.

4. Results and discussion

The obtained plots of recorded temperature variations with time are shown in Figs. 7-10. The vertical axes with temperature were prepared to have the same range of 293 to 300 K (for 4 mm thick specimens) and 293 to 299 K (for 5 mm thick specimens) for both heating conditions (A and B), clearly showing the differences between temperature increase in both cases.

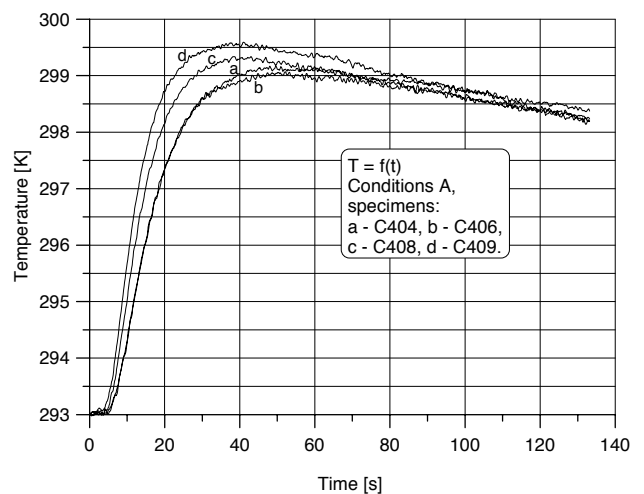

Fig. 7. Temperature variations with time for: a) C404, b) C406, c) C408, d) C409 specimens (conditions A)

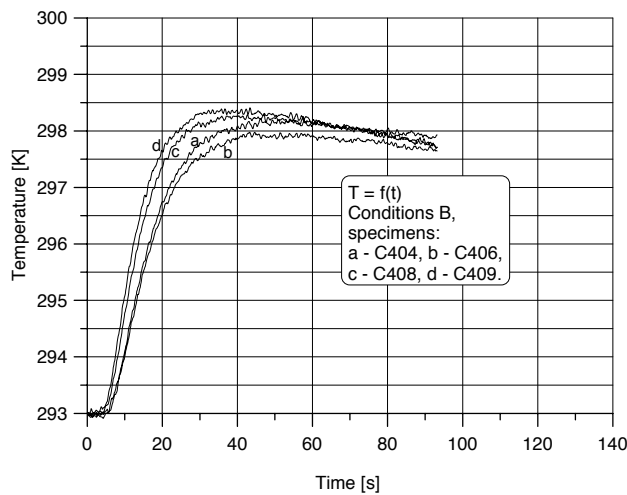

Fig. 8. Temperature variations with time for: a) C404, b) C406, c) C408, d) C409 specimens (conditions B)

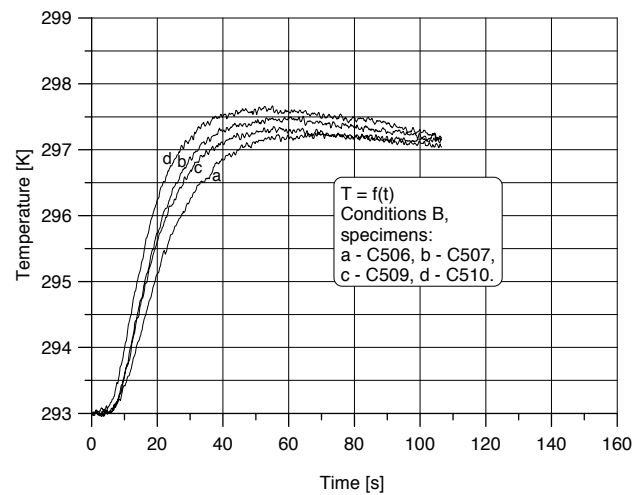

Fig. 10. Temperature variations with time for: a) C506, b) C507, c) C509, d) C510 specimens (conditions A)

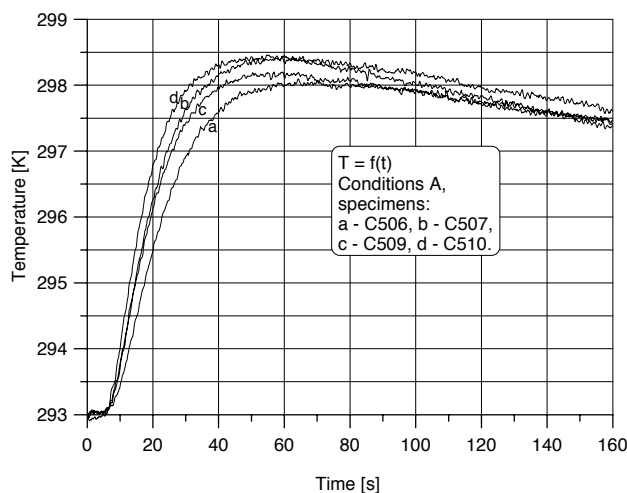

Fig. 9. Temperature variations with time for: a) C506, b) C507, c) C509, d) C510 specimens (conditions A)

For example, the temperature increase for C409 specimen is equal to about 6.6 K (conditions A) in comparison with about 5.4 K for the same specimen but in the case of conditions B (see Figs. 7 and 8). In both cases the linear temperature response is clearly seen. The similar situation can be observed for 5 mm thick specimens in Figs. 9 and 10. The transposed sequence of temperature variation plots (b, a, c, d, for 4 mm thick specimens, Figs. 7 and 8) for specimens with an increasing fibre content is due to the effect of differences in thickness of the specimens (see Table 2). The similar transposed sequence of plots (a, c, b, d) is observed for 5 mm thick specimens (Figs. 9 and 10).

From all presented plots of temperature variations versus time, the dimensionless temperature history plots were created according to the procedure described in other publications [3,4] and standard [18].

For two specimens with near-thickness, the thermal images (Figs. 3-6) were prepared to present obtained differences in temperature represented by different colour distributions on specimen surface. The thermal images were captured at the same time counting from the beginning of heating process.

The presented thermal images consist of a view of the heated specimen (centre of the image) and the neighbourhood. At the time of 0 seconds to about 4 seconds the specimen as well as the neighbourhood were represented by the same colour on thermal images due to the same temperature and the same mat black coating. The images were prepared as a comparison of two cut images and connected together showing temperature differences.

Presented thermal images were captured at the time of 10.0 and 20.0 seconds (for 4 mm thick specimen, Figs. 3, 4) and 15.3 and 26.6 seconds (for 5 mm thick specimen, Figs. 5, 6) counting from the beginning of the heating process.

These images were chosen to be representative from all captured images due to the near-thickness of the specimens (C404 and C408, C507 and C510).

It was clearly seen from thermal images captured at the same time, that for each specimen, the higher is carbon content the higher is the temperature obtained (area 1 and area 2). Other differences such as temperature growth rate can be only observed on "temperature variations versus time" plots (Figs. 3-6) obtained during the temperature recording for all investigated specimens.

Figures 11-18 show the plots of dimensionless temperature history at the rear surface for all specimens studied only for conditions A due to the similarity with plots corresponding to conditions B. It can be seen that considered values of time $t_{0.5}$ and $t_{0.3}$ as well as slopes of straight lines needed for thermal diffusivity calculations, in general, decrease with an increase of fibre content in composite specimens.

The effect of thickness differences for specimen can be observed in the cases where values of $t_{0.5}$ (or $t_{0.3}$) are similar for different specimens (including different fibre content, e.g. C404 and C406 or C507 and C509). This situation is insignificant because the thermal diffusivity calculations take into account specimen's thickness according to Equation 5 and 6.

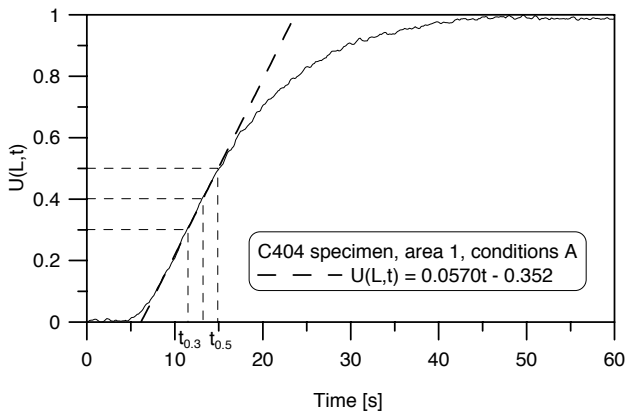

Fig. 11. Dimensionless temperature history at the rear surface of C404 specimen for area 1 and conditions A

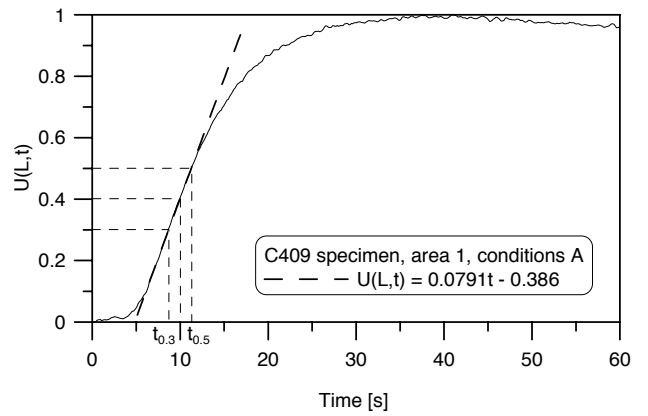

Fig. 14. Dimensionless temperature history at the rear surface of C409 specimen for area 1 and conditions A

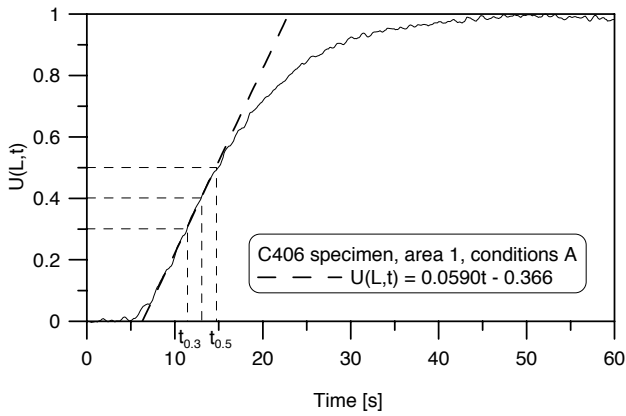

Fig. 12. Dimensionless temperature history at the rear surface of C406 specimen for area 1 and conditions A

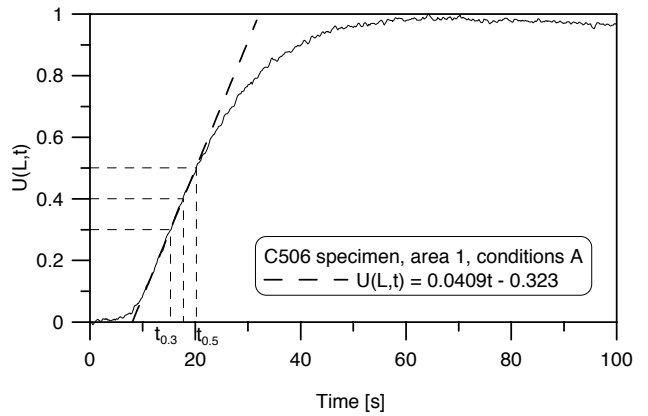

Fig. 15. Dimensionless temperature history at the rear surface of C506 specimen for area 1 and conditions A

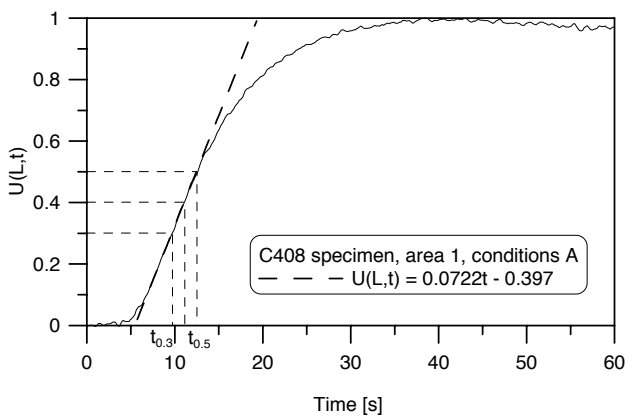

Fig. 13. Dimensionless temperature history at the rear surface of C408 specimen for area 1 and conditions A

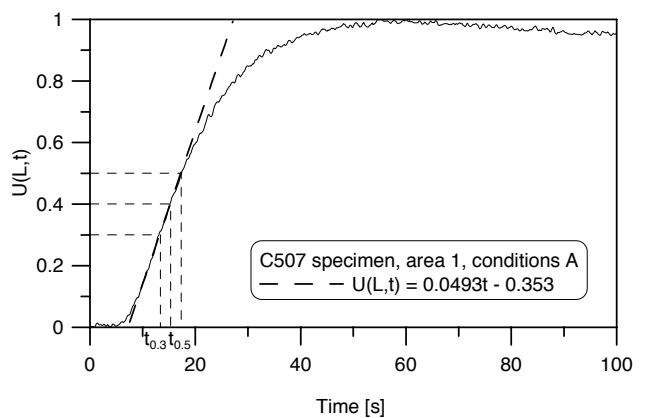

Fig. 16. Dimensionless temperature history at the rear surface of C507 specimen for area 1 and conditions A

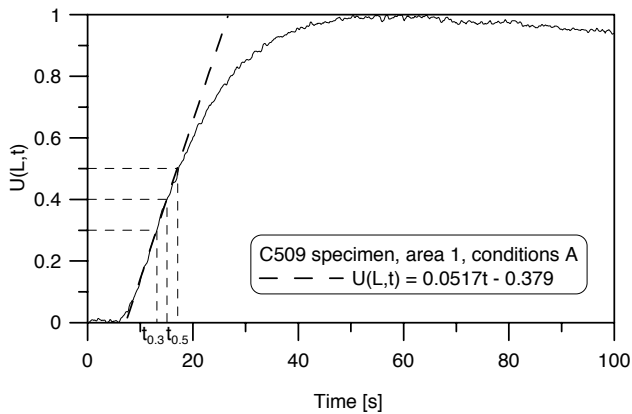

Fig. 17. Dimensionless temperature history at the rear surface of C509 specimen for area 1 and conditions A

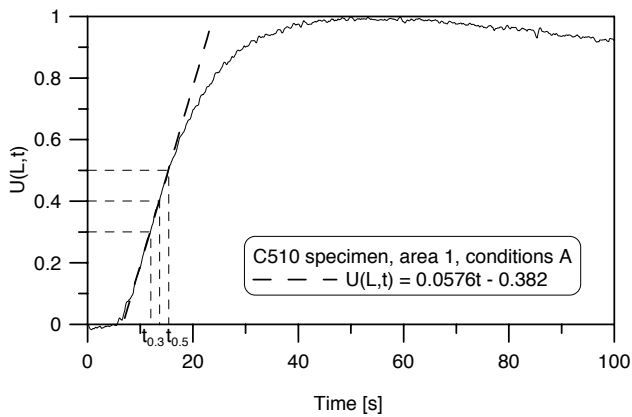

Fig. 18. Dimensionless temperature history at the rear surface of C510 specimen for area 1 and conditions A

The $t_{0.5}$ and $t_{0.3}$ values taken from normalized temperature increase plots together with specimen thickness (L) were used to calculate the thermal diffusivity values according to Parker's Equation (Eq. 5, presented above) and Eq. 6 corresponding to temperature rise of $U = 0.3$, it is

$$\alpha = 0.99L^2/\pi^2t_{0.3} \tag{6}$$

Obtained values of the thermal diffusivity (shown in Figs. 19-22) show that the higher the carbon content the higher are the thermal diffusivity values. These results have been further processed using standard regression technique to obtain the best fitting lines, which equations are presented in legends (Figs. 19-22).

There are insignificant (less than 4%) differences between thermal diffusivity values for $t_{0.5}$ and $t_{0.3}$, indicating that effects of thermal losses caused by long heating pulse time, radiant energy penetration or relatively high temperature increase on rear surface can be neglected. In order to obtain higher accuracy of results there is necessity to introduce the corrections into calculations as was recommended in standard [18].

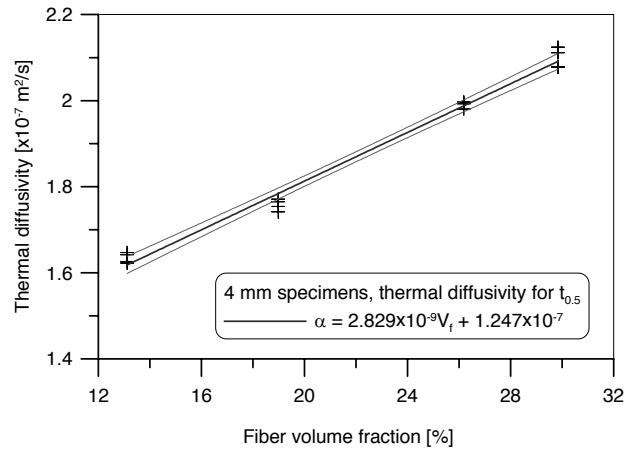

Fig. 19. Thermal diffusivity as a function of fiber content for: C404, C406, C408, C409 specimens, calculated for $t_{0.5}$

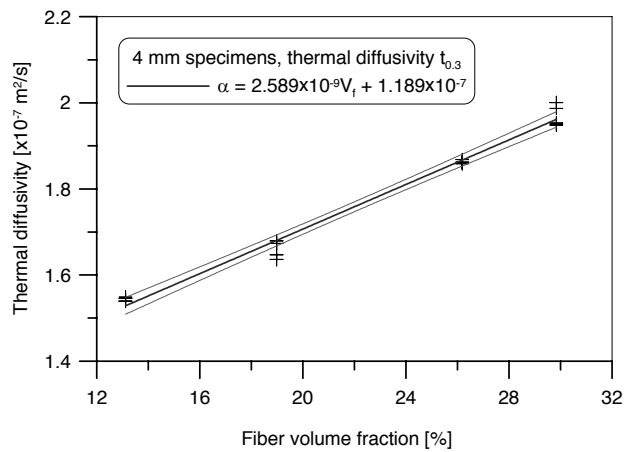

Fig. 20. Thermal diffusivity as a function of fiber content for: C404, C406, C408, C409 specimens, calculated for $t_{0.3}$

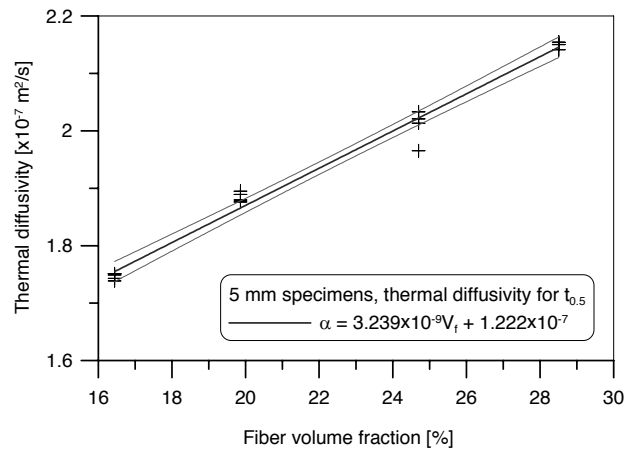

Fig. 21. Thermal diffusivity as a function of fiber content for: C506, C507, C509, C510 specimens, calculated for $t_{0.5}$

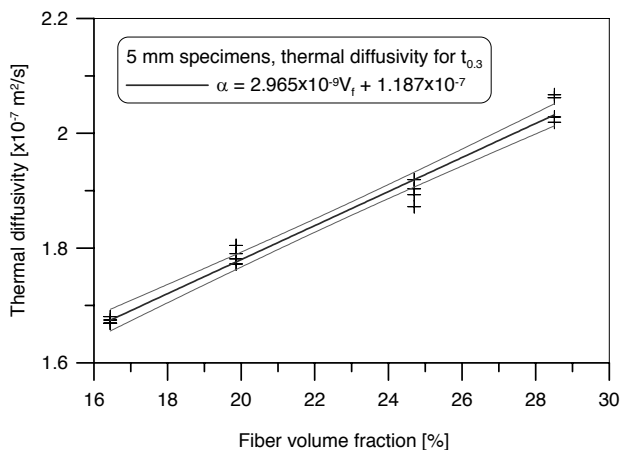

Fig. 22. Thermal diffusivity as a function of fiber content for: C506, C507, C509, C510 specimens, calculated for $t_{0.3}$

It is worth to note that the straight line equations presented in legends can be converted to obtain equations able to determine fibre content V_f putting as a value of α the experimentally evaluated thermal diffusivity by transient method, which was done in previous authors' publication [12]. That indicates the application possibility of transient thermography as a non-destructive testing (NDT) technique of fibre content (or fibre displacement) determination in carbon/epoxy composite materials.

5. Conclusions

In the present study, the transient thermography was used to measure the thermal diffusivity of CFRP composites with different fibre content. The method initially proposed by Parker et al. as "flash method" for the thermal diffusivity measurements of homogeneous solids was successfully applied to determine thermal diffusivity values of non-homogeneous carbon/epoxy composites. Relationship showed that the thermal diffusivity is linear function of carbon content in considered materials.

References

- [1] F. Cernuschi, P.G. Bison, A. Figari, S. Marinetti, E. Grinzato, Thermal diffusivity measurements by photothermal and thermographic techniques, *International Journal of Thermophysics* 25/2 (2004) 439-445.
- [2] M. Navarrete, F. Serrania, M. Villgran, Application of the flash method for the thermal characterisation of woven carbon fibre laminates, *Materials and Design* 22 (2001) 93-97.
- [3] W.J. Parker, R.J. Jenkins, C.P. Butter, G.L. Abbot, Flash method of determining thermal diffusivity, heat capacity and thermal conductivity, *Journal of Applied Physics* 32 (1961) 1679-1684.
- [4] W.N. dos Santos, P. Mummery, A. Wallwork, Thermal diffusivity of polymers by the laser flash technique, *Polymer Testing* 24 (2005) 628-634.
- [5] B. Weidenfeller, M. Hofer, F.R. Schilling, Thermal conductivity, thermal diffusivity, and specific heat capacity of particle filled polypropylene, *Composites: Part A* 35 (2004) 423-429.
- [6] R.P. Brady, M.R. Kulkarni, Determination of thermal diffusivity distribution for three types of materials by transient thermography, *Independent Nondestructive Testing and Evaluation International* 29 (1996) 205-211.
- [7] D. Bates, G. Smith, D. Lu, J. Hewitt, Rapid thermal non-destructive testing of aircraft components, *Composites: Part B* 31 (2000) 175-185.
- [8] M. Krishnapillai, R. Jones, I.H. Marshall, M. Bannister, N. Rajic, Thermography as a tool for damage assessment, *Composite Structures* 67 (2005) 149-155.
- [9] G. Muzia, Z. Rdzawski, M. Rojek, J. Stabik, G. Wróbel, Thermographic diagnosis of fatigue degradation of epoxy-glass composites, *Journal of Achievements in Materials and Manufacturing Engineering* 24/2 (2007) 123-126.
- [10] J. Kaczmarczyk, M. Rojek, G. Wróbel, J. Stabik, A model of heat transfer taking place in thermographic test stand, *Journal of Achievements in Materials and Manufacturing Engineering* 27/1 (2008) 7-14.
- [11] G. Wróbel, G. Muzia, S. Pawlak, Active IR-thermography as a method of fiber content evaluation in carbon/epoxy composites, *Archives of Materials Science and Engineering* 30/2 (2008) 101-104.
- [12] G. Wróbel, Z. Rdzawski, G. Muzia, S. Pawlak, The application of transient thermography for the thermal characterisation of carbon fibre/epoxy composites, *Journal of Achievements in Materials and Manufacturing Engineering* 36/1 (2009) 49-56.
- [13] L.A. Dobrzański, A. Pusz, A.J. Nowak, Aramid-silicon laminated material with special properties – new perspective of its usage, *Journal of Achievements in Materials and Manufacturing Engineering* 28/1 (2008) 7-14.
- [14] W. Hufenbach, L.A. Dobrzański, M. Gude, J. Konieczny, A. Czulak, Optimization of the rivet joints of the CFRP composite material and aluminium alloy, *Journal of Achievements in Materials and Manufacturing Engineering* 20 (2007) 119-122.
- [15] K. Jamroziak, M. Bocian, Identification of composite materials at high speed deformation with the use of degenerated model, *Journal of Achievements in Materials and Manufacturing Engineering* 28/2 (2008) 171-174.
- [16] S.B. Heru, J. Komotori, M. Shimizu, Y. Miyano, Effects of the fiber content on the longitudinal tensile fracture behavior of uni-directional carbon/epoxy composites, *Journal of Materials Processing Technology* 67 (1997) 89-93.
- [17] O.I. Okoli, G.F. Smith, Failure modes of fibre reinforced composites: The effect of strain rate and fibre content, *Journal of Materials Science* 33 (1998) 5415-5422.
- [18] PN-EN 821-2:2002, Advanced technical ceramics – Monolithic ceramics – Thermo-physical properties – Part 2: Determination of thermal diffusivity by the laser flash (or heat pulse) method.