

Non-destructive method of determination of elastic properties and adhesion coefficient of different coating materials

M. Kubisztal ^a, A. Chrobak ^{b,*}, G. Haneczok ^a

^a Institute of Materials Science, Silesian University,
ul. Bankowa 12, 40-007 Katowice, Poland

^b Institute of Physics, Silesian University,
ul. Uniwersytecka 4, 40-007 Katowice, Poland

* Corresponding author: E-mail address: artur.chrobak@us.edu.pl

Received 15.10.2010; published in revised form 01.12.2010

Methodology of research

ABSTRACT

Purpose: The paper presents a non-destructive method of determination of Young's modulus and adhesion coefficient of different coating materials (metallic coatings, polymer, composite etc.). Some of the results obtained by applying this method are discussed in detail.

Design/methodology/approach: The presented method consists in measuring the dynamic response of the examined material in the form of a flat rectangular bar subjected to external periodic mechanical stress i.e. the so called vibrating reed technique. General equations describing elastic properties of the sample consisting of a substrate and a deposited coating are derived and discussed in detail.

Findings: It was shown that the application of the proposed approach to the metallic, polymeric and composite coatings allowed to obtain a quantitative data concerning the change of both the elastic properties and the adhesion coefficient with a change of: coating thickness, measurement temperature, chemical composition of coating, surface preparation or in the case of epoxy resin coatings with a change of curing time or curing temperature.

Research limitations/implications: The proposed method can be applied in many scientific problems in the field of coating materials (e.g. elastic properties of porous coating, crystallization of amorphous coating, adhesion of different polymeric coatings).

Practical implications: It was shown that the described method can be successfully used in optimisation of some technological processes of deposition of different coatings on metallic substrate.

Originality/value: The paper presents methodology of a non-destructive approach to determination of elastic properties and adhesion coefficient of coating materials with an overview of some applications already published and also the new ones. Especially interesting are the results concerning the influence of surface preparation on adhesion coefficient which are published for the first time.

Keywords: Coating materials; Elastic properties; Young's modulus; Adhesion coefficient; Free vibrations

Reference to this paper should be given in the following way:

M. Kubisztal, A. Chrobak, G. Haneczok, Non-destructive method of determination of elastic properties and adhesion coefficient of different coating materials, Journal of Achievements in Materials and Manufacturing Engineering 43/2 (2010) 634-643.

1. Introduction

The development of modern technologies requires new materials prepared for specific technical applications. In this respect, coating materials exhibit increasing importance as coating properties can improve many characteristics of the substrate-coating system. Many properties of these coating materials are superior to substrate, namely corrosion resistance, hardness, roughness or smoothness etc. The determination of mechanical properties (Young's modulus) and/or adhesion coefficient for coating materials is of great importance from both scientific and practical points of view. On the one hand, the knowledge of these parameters allows to control the deposition process (e.g., via its optimization) and, on the other hand, allows controlling the layer properties as well as the substrate-coating system properties. The most important parameters of modern coating materials, irrespective of the fabrication method, are a good coating adhesion and a good creep resistance. Most of the known methods for determination of the adhesion coefficient and Young's modulus are sample destructive and base on measuring an indentation depth or a force (energy) necessary for splitting the layer from the substrate.

In this study, the general methodology of Young's modulus and adhesion coefficient determination by applying a vibrating reed technique as a non-destructive method (theory and experiment) is presented. The paper demonstrates and discusses in detail some well selected applications of the technique basing on the measurements of the free flexural vibration frequency of the sample mounted in the apparatus in the clamped-free configuration. In section 2 - theoretical background - a set of equations describing elastic properties of different kinds of coatings is presented and discussed in detail. It was demonstrated that the general case can be simplified to the case valid for polymer coating on a metallic substrate.

In the next sections the applications of the presented methodology to the known problems in materials science engineering are shown. Application of the proposed approach to the metallic, polymeric and composite coatings allowed obtaining a quantitative data concerning the change of both the elastic properties and the adhesion coefficient with a change of: coating thickness, measurement temperature and chemical composition of the coating. Especially interesting are the results concerning the influence of surface preparation on adhesion coefficient which are published for the first time.

2. Theoretical background

Elastic properties of any material in the form of a flat bar can be determined by measuring the frequency of the sample excited into free vibrations. A suitable apparatus called vibrating reed is described e.g. in [1-3]. In general, equation of motion for such a vibrating sample is in the form [1, 2]:

$$\frac{\partial^4 Y(x,t)}{\partial x^4} + \zeta^2 \frac{\partial^2 Y(x,t)}{\partial t^2} = 0, \quad (1a)$$

where $Y(x,t)$ is amplitude of vibration, and

$$\zeta = \sqrt{\frac{\mu_s}{K_s}}, \quad (1b)$$

where μ_s - mass per unit length and K_s - bending stiffness. From equation (1) one can obtain the relation for free vibration frequency f_s of the sample in clamped-free configuration, which is in the form:

$$(2\pi f_s)^2 = \frac{(2\alpha_n/l)^4}{\zeta^2}, \quad (2)$$

where l is the vibrating length of the reed, α_n is the vibration mode which takes the values $\alpha_1 = 0.29843\pi$, $\alpha_2 = 0.74709\pi$, $\alpha_3 = 1.25013\pi$, and for $n > 3$, we can use general equation, that is:

$$\alpha_n = (n - \frac{1}{2})\pi/2, \quad (3)$$

Note, that for a sample with a rectangular section (i.e. when $K_s = E_s I_s = E_s b d_s^3 / 12$ where b , d_s , I_s and E_s are the sample breadth, the sample thickness, the second moment of area of a cross-section about the neutral axis and the Young's modulus of the examined material) we have:

$$f_s^2 = \frac{1}{3} \left(\frac{\alpha_n^2 d_s}{\pi l^2} \right)^2 \frac{E_s}{\rho_s}, \quad (4)$$

where ρ_s is the material density. Eq. (4) is widely used for determination of the Young's modulus of any material via measuring the frequency of free vibration f_s .

In the case of coating materials (i.e. substrate with deposited coating) one has to introduce the frequency f_c measured for substrate with the coating which according to Berry [4] is connected with the frequency f_s (measured for substrate only) via the following formula valid for coating deposited on both sides of the substrate:

$$\frac{f_c^2}{f_s^2} = \frac{K_c / K_s}{\mu_c / \mu_s} = \frac{1 + K_f / K_s}{1 + \mu_f / \mu_s}, \quad (5)$$

where suffix c stands for substrate-coating reed, and suffix f stands for deposited coating. Fig. 1 depicts the general form of the trilayer reed with a location of the neutral axis.

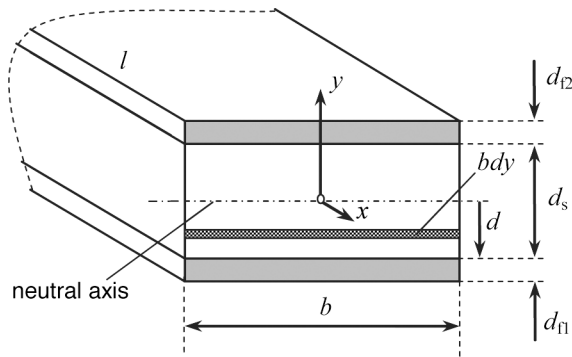

Fig. 1. General form of the trilayer reed, d_{f1}, d_{f2} - are thicknesses of the coatings, d_s - thickness of the substrate b - breadth and l - length of the reed, d - location of the neutral axis

According to [4] a substantial advantage is gained by the imposition of symmetry i.e. when trilayer reed is represented by the conditions $d_{f1}=d_{f2}=d_f$ and $E_{f1}=E_{f2}=E_f$, where d_f is coatings thickness and E_f is Young's modulus of the coatings (see Fig.1). This has immediate and obvious consequence that the neutral surface lays at the mid plane of the substrate, and for the stiffness factor we obtain:

$$\frac{K_f}{K_s} = \{ [1 + (2d_f / d_s)]^3 - 1 \} (E_f / E_s), \tag{6}$$

For completeness, we note that the inertia factor appearing in eq. (5) for symmetrical trilayer case, is given by:

$$\frac{\mu_f}{\mu_s} = 2d_f \rho_f / d_s \rho_s, \tag{7}$$

Additionally, if the thickness of the deposited coating is restricted by the ratio $d_f / d_s \ll 1$ then the eq. (5) takes the form:

$$(f_c^2 - f_s^2) / f_s^2 = n_f \left(\frac{3E_f}{E_s} - \frac{\rho_f}{\rho_s} \right) \frac{d_f}{d_s}, \tag{8}$$

where coefficient $n_f = 2$ means that both sides of the substrate are covered by the coating. As it can be seen from eq. (8) elastic properties of the coatings i.e. E_f can be determined from independent measurements of free vibrations frequency of the substrate (i.e. f_s) and the free vibrations frequency of the substrate-coating system (i.e. f_c).

It should be emphasized that eq. (8) proposed by Berry assumes that the deformation of the composite reed during vibrations evokes continuous transfer of the elastic energy from the substrate to the coating. In practice situation is usually different. Not perfectly adhered coating causes the dissipation of elastic energy and in consequence a decrease of frequency f_c . In the works [5, 6] the eq. (8) was revised by introducing the adhesion coefficient γ that takes the values between 0 (not

adhered coating with deformation 0) and 1 (for perfectly adhered coating). So, according to the Wuttig proposal the eq. (8) should be rewritten in the form:

$$\frac{f_c^2}{f_s^2} = \left(\frac{3\gamma^2 E_f}{E_s} - \frac{\rho_f}{\rho_s} \right) \frac{d_f}{d_s} + 1. \tag{9}$$

This equation is usually used to describe elastic properties of thin metallic coatings deposited on the one side of a metallic substrate. In the case of not symmetrical trilayer reed (i.e. $d_{f1} \neq d_s \neq d_{f2}$ and $E_{f1} \neq E_s \neq E_{f2}$, see Fig. 1) with different coatings adhesion coefficient γ and β the relation between f_s and f_c was given in the work [1, 7]:

$$\frac{f_c^2}{f_s^2} = \left(\frac{\gamma^2 K_{f1}^c + K_s^c + \beta^2 K_{f2}^c}{K_s} \right) \cdot \frac{\mu_s}{\mu_c}, \tag{10}$$

where the inertia factor

$$\frac{\mu_s}{\mu_c} = \frac{\rho_s d_s}{\rho_{f1} d_{f1} + \rho_s d_s + \rho_{f2} d_{f2}}, \tag{11}$$

The adhesion coefficients γ and β are defined according to Wuttig as:

$$\gamma = \frac{\epsilon_{F1}}{\epsilon_{f1}} \text{ and } \beta = \frac{\epsilon_{F2}}{\epsilon_{f2}}, \tag{12}$$

where ϵ_{F1} and ϵ_{F2} is the deformation of the coating at its partial adherence to the substrate and ϵ_{f1} and ϵ_{f2} stands for deformation of the coating that is ideally adhered to the substrate. Bending stiffness values that appear in eq. (10) can be derived by calculation the appropriate integrals of the second moment of area I of a cross-section about the neutral axis. So we have:

$$K_s = E_s I_s = E_s \int_{-d_s/2}^{d_s/2} y^2 dS = E_s \int_{-d_s/2}^{d_s/2} y^2 b dy = \frac{1}{12} b d_s^3 E_s \tag{13a}$$

$$K_{f1}^c = E_{f1} I_{f1}^c = E_{f1} \int_{-d-d_{f1}}^{-d} y^2 b dy = E_{f1} b \left(\frac{d_{f1}^3}{3} + d^2 d_{f1} + d d_{f1}^2 \right) \tag{13b}$$

$$K_s^c = E_s I_s^c = E_s \int_{-d}^{d_s-d} y^2 b dy = E_s b \left(\frac{d_s^3}{3} - d_s^2 d + d_s d^2 \right) \tag{13c}$$

$$K_{f2}^c = E_{f2} I_{f2}^c = E_{f2} \int_{d_s-d}^{d_s-d+d_{f2}} y^2 b dy = \tag{13d}$$

$$\frac{1}{3} E_{f2} b [(d - d_s)^3 + (d_s - d + d_{f2})^3]$$

where d determines location of the neutral axis (see Fig. 1). It is clear that during the flexural vibrations the forces perpendicular to the cross section of the sample are in equilibrium so the d value can be obtained by solving the equation:

$$\frac{b}{r} \left(\int_{-d-d_{f1}}^{-d} E_{f1} y dy + \int_{-d}^{d_s-d} E_s y dy + \int_{d_s-d}^{d_s-d+d_{f2}} E_{f2} y dy \right) = 0, \quad (14)$$

where $1/r$ is the static uniform curvature produced by a bending moment, and we have:

$$d = \frac{E_{f1} d_{f1}^2 - E_s d_s^2 - E_{f2} (2d_{f2} d_s + d_{f2}^2)}{-2(E_{f1} d_{f1} + E_s d_s + E_{f2} d_{f2})}, \quad (15)$$

It is clear that for the restrictions $d_{f2}=0$ and $d_{f1}/d_s \ll 1$ the neutral axis of the reed is located near the mid plane of the substrate (i.e. $d \approx d_s/2$) and in consequence equation (10) leads to the known Berry-Wuttig equation (9). In practice, for the coatings with the values of the $E_{f1} \approx E_s$ and with the ratio d_{f1}/d_s up to 10% those equations are well fulfilled, however thicker coatings causes that the relation $d \approx d_s/2$ is not correct and in result the error incorporated in elastic properties determination strongly increases. According to [1, 7] the restriction concerning the neutral axis can be also fulfill for $E_{f1}/E_s \ll 1$. This case seems to be especially interesting for many polymeric coatings deposited on metallic substrate. Fig. 2 shows the position of the neutral axis as a function of both coating thickness and the ratio E_f/E_s determined theoretically for a substrate with a typical thickness $d_s = 0.5$ mm. It is seen that neutral axis is placed near the mid plane of the substrate ($d \approx d_s/2 \approx 0.25$ mm) not only for the restriction $d_{f1}/d_s \ll 1$ but also for $E_{f1}/E_s \ll 1$. Taking this fact into account for $d_{f2} = 0$ the equation (10) simplify to [1, 7, 8]:

$$\frac{f_c^2}{f_s^2} = \frac{\rho_s (\gamma^2 E_f (4d_f^3 + 3d_f d_s^2 + 6d_s d_f^2) + E_s d_s^3)}{E_s d_s^2 (\rho_f d_f + \rho_s d_s)}, \quad (16)$$

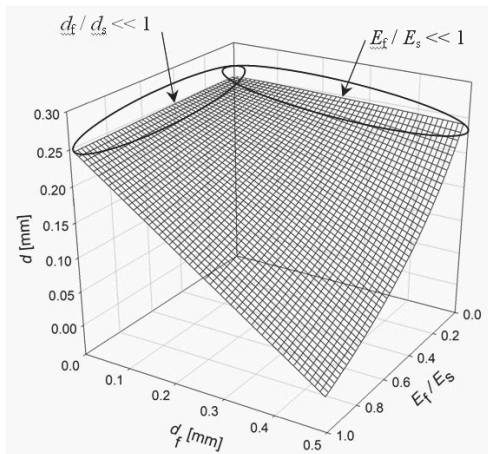

Fig. 2. Position d of the neutral axis in a function of coating thickness d_f and the ratio E_f/E_s for a substrate with $d_s = 0.5$ mm

It should be emphasized that the value E_f appearing in equations (8), (9) and (16) can not be identify with the Young's modulus of the bulk material i.e. E_f' . It is a simple consequence of the fact that the coating deformation depends on the elastic properties of the substrate, and we have [1, 9]:

$$\frac{E_f}{E_f'} = \frac{1 - \nu_s \nu_f}{1 - \nu_f^2}, \quad (17)$$

where ν_s and ν_f are the Poisson coefficients for the substrate and the coating, respectively. For better presentation of eq. (17) the dependence of the ratio E_f/E_f' on the values of ν_s i ν_f is presented in Fig. 3. It can be seen that the highest difference between E_f i E_f' (slightly above 30 %) can be observed for the highest value of ν_f (0.5) and relatively low values of ν_s (≈ 0).

In general, the product $\gamma^2 E_f$ in eq. (9) and (16) describes elastic properties of a given coating on a given substrate by taking into consideration both the adhesion coefficient and the Young's modulus of coating material. From this point of view the product $\gamma^2 E_f$ is called the apparent Young's modulus. It is obvious that the apparent Young's modulus can be used in order to determine the so-called relative adhesion coefficient defined as [11]:

$$\gamma_r^2 = \frac{\gamma_2^2 E_f}{\gamma_1^2 E_f'} = \frac{\gamma_2^2}{\gamma_1^2}, \quad (18)$$

where γ_1 and γ_2 are adhesion coefficients for two different coatings with the same E_f . It seems to be clear that equation (18) can be applied to optimize the technological process of coating deposition.

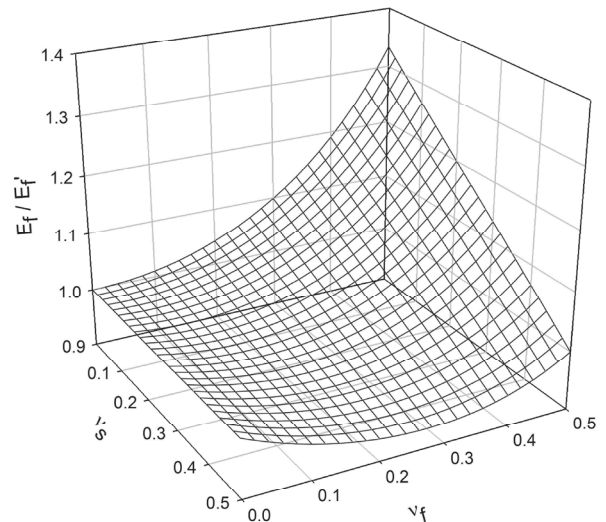

Fig. 3. The ratio E_f/E_f' (E_f, E_f' - Young's modulus of the coating deposited on the substrate and detached from the substrate, respectively) versus ν_s and ν_f i.e. Poisson coefficients of the substrate and the coating

Indeed, a series of coatings prepared of the same material (the same E_f) using different deposition conditions should exhibit different apparent modulus due to different adhesion coefficients. According to equation (18) the relative adhesion coefficient γ_r determines quantitatively which coating has better adhesion in relation to the coating arbitrary taken as the reference one. Obviously $\gamma_r > 1$ means that the examined coating shows better adhesion than the reference one. This approach allows studying the change of the adhesion coefficient with different external parameters like coating thickness, temperature, pressure etc.

3. Experimental technique

It was already mentioned that measurements of free vibration frequency f_s of a sample in the form of a flat rectangular bar allow determining Young's modulus of the examined material by making use of equation (4) [1-3]. The sample of the shape shown in Fig. 4 is excited into flexural vibration with amplitude corresponding to deformation of the order of 10^{-5} . Frequency of free vibration can be measured by applying for example a capacity converter for which the sample is one of the electrodes [1, 2]. In a typical procedure the frequency f_s is measured versus temperature with a constant heating rate.

In the case of coating materials the application of equation (9) or (16) requires the following measurement procedure: i) the frequency f_s (substrate only) should be measured (for example versus temperature) before coating deposition and ii) for the same substrate after the coating deposition the frequency f_c is measured (again versus temperature).

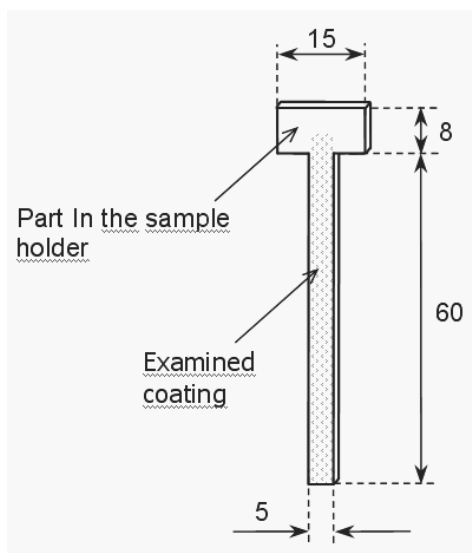

Fig. 4. Sample shape used in vibrating reed measurements [10]; all dimensions are given in mm

In this kind of measurements a separate issue is the sample mounting which has to ensure that the frequencies f_s and f_c are not disturbed by an undefined error resulting from e.g. the

operation of sample removing out of the sample holder for coating deposition. Obviously the error connected with sample mounting plays more important role in the case in which f_c and f_s do not differ very much. It has to be stressed that the T-shaped sample proposed in [10] and shown in Fig. 4, gives sufficient precision in determination of the both frequencies i.e. f_s and f_c . It gives a double profit: i) the sample length is always constant and ii) the stress induced by sample holder in the point contact, sample – sample holder, does not influence the sample vibrations.

4. Applications

The vibrating reed technique, together with the methodology based on equations described in previous section give very useful tool to examination of the elastic properties and the adhesion coefficient of different coating materials. In this section the application of such approach to some problems in materials science is presented and discussed. The attention is focused on the results obtained for different metallic (Ni, Ni-P), polymeric (epoxy resin, oil-color) and composite (Ni+Mo, epoxy resin plus Fe powder) coatings.

4.1. Metallic coatings

Amorphous Ni-P coatings can be obtained from aqueous solutions using the known electroless deposition method. These coatings are very interesting from application point of view because many of their properties are superior to the coatings obtained by applying electroplating methods. In this context one has to list better corrosion resistance, good adhesion even to the rough surfaces and higher hardness [11, 12].

A detailed study of elastic properties of Ni-P coatings were carried out in [11]. The coatings were deposited on both sides of the stainless steel substrate with thickness $d_s = 500 \mu\text{m}$ while the coating thicknesses in all cases do not exceed $15 \mu\text{m}$. It was shown using X-ray diffraction method that just after the deposition all of the studied coatings were amorphous. Measurements of free vibration frequency versus temperature (up to 700 K with heating rate 3 K/min.) were carried out using vibrating reed technique (see section 3) [1]. In order to determine Young's modulus of the coatings material the analysis based on the procedure described in section 2 was performed. It was assumed that $d_{f1} = d_{f2} = d_f$, $E_{f1} = E_{f2} = E_f$ and $\gamma = \beta$ (trilayer symmetrical case, with additional restriction $d_f/d_s \ll 1$).

Fig. 5a shows the relation f_s^2 (according to eq. (4) f_s^2 is proportional to E_s) and f_c^2 versus temperature obtained for Ni-P coating with thickness $d_f = 15 \mu\text{m}$. It can be seen that $f_s^2(T)$ monotonically decreases with increasing temperature just as it should be expected for temperature dependence of Young's modulus of a solid state. However, the values $f_c^2(T)$ exhibit an increase in temperature range 550-590 K. In [11] it was stated that this increase is related to crystallization of Ni coating (amorphous just after deposition) and to formation of nickel phosphide Ni_3P that occurs at higher temperatures. Fig. 5b shows the apparent Young's modulus determined for the same sample in the temperature range 300 K-700 K. One can see that the observed

increase in f_c^2 which is a few percent corresponds to a change in $\gamma^2 E_f$ value of about 45 %. The value of Young's modulus at room temperature $E_f=112$ GPa determined in [11] for amorphous Ni-P coating, is in agreement with the value of $E_f^r=135$ GPa determined by means of nano-indentation method.

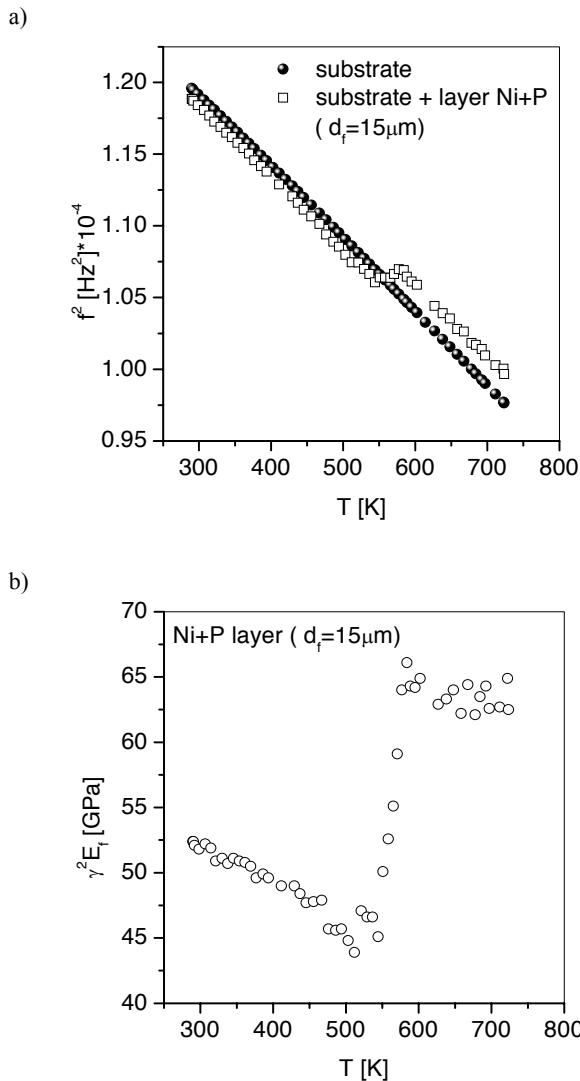

Fig. 5. a) Square of free vibration frequency determined for stainless steel substrate $f_s^2(T)$ and deposited Ni-P coating versus temperature, and b) the apparent Young's modulus $\gamma^2 E_f$ versus temperature for the same coating [11]

The data presented in Fig. 5 shows that the apparent Young's modulus of the examined coating after crystallization increases about 45%. This means that elastic properties of the coating are correspondingly better due to an increase of the adhesion coefficient or/and Young's modulus. It has to be stressed that from application point of view important is the fact that the Ni-P

coating after a suitable annealing enhances elastic properties. The question which part of this enhancement is due to an increase of γ and which part is due to an increase of the modulus E_f has a minor meaning. Nevertheless in some cases it can be settled which is presented below.

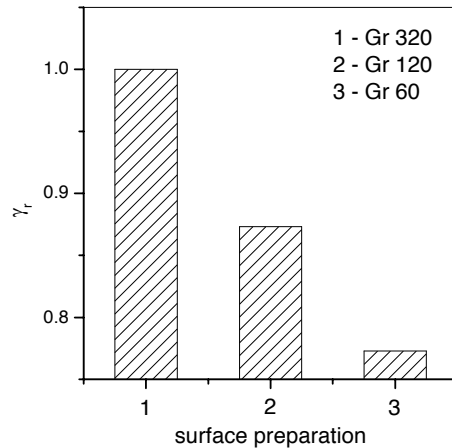

Fig. 6. Relative adhesion coefficient γ_r determined for Ni coating electroplated on carbon steel substrate with different surface preparation: Gr-grinding with abrasive paper (grit 60, 120 and 320)

It is obvious that adhesion coefficient should strongly depend on preparation of the contact surface between coating and substrate. This effect can be studied by applying the idea of relative adhesion coefficient defined by eq. (18). Indeed, one can prepare the same coatings i.e. with the same modulus E_f , on the same substrate (the same E_s) but with different adhesion. The latter can be change by different preparation of the contact surface. Such results are presented in Fig. 6 where the relative adhesion coefficients γ_r determined for Ni coating deposited on the carbon steel substrate with different contact surface preparation (i.e. - grinding (Gr) with abrasive paper - grit 60, 120 and 320) are shown. It can be seen that adhesion of the coating strongly decreases - up to 80 % - with increasing grit of the abrasive paper. The observed effect has obviously an important practical meaning.

4.2. Polymer coatings

Epoxy polymers (i.e. epoxy resin plus hardener) are very interesting materials because of some specific chemical and physical properties such as a low thermal expansion, a good chemical corrosion resistance and also a good electrical resistance. Epoxy systems find applications as protective coatings, adhesives for joining various engineering elements and also as matrices for composite materials. Special properties of the epoxy materials result from the highly crosslinked network structures. Three dimensional network is formed at the gel point, marked by a sudden and irreversible change from a viscous liquid to an elastic gel during chemical reaction of the epoxy resin and the

appropriate hardener. Additionally, during the reaction one can observe a decrease of free volume content what influences elastic properties of any epoxy material.

The change in elastic properties taking place during the curing reaction can be easily studied by applying the procedure presented in this work. In this case sample consists of a substrate with deposited coating of an epoxy material in a liquid form. Frequency of free vibration of such sample can be measured versus time at constant temperature during the curing reaction. The constant temperature guarantees that a possible change of the substrate modulus E_S does not mask the change of the coating modulus E_f caused by the curing process. Taking into account the fact that the curing process is a highly exothermic reaction the proposed approach seems to be especially advantageous because a thin layer on a metallic substrate allows avoiding a spontaneous self-heating of the examined sample. This effect (much more important for massive samples) may cause that the reaction temperature is not well controlled, and what follows, the obtained results are not reliable enough. Moreover, the measurements of free vibrations frequency allows to calculate some important technical parameters like shear modulus, apparent Young's modulus or adhesion coefficient of the coating to the substrate

In the work [7] commercially available epoxy material with the trademark Loctite Hysol 3423 was investigated as a coating deposited on alumina alloy EN AW-5251 by applying inverted torsion pendulum (working at frequency c.a. 1 Hz). Fig. 7 shows the change of free vibration frequency f measured versus time during the curing reaction at two different temperatures i.e. $T_C = 296$ K and $T_C = 306$ K (for detail see [1, 13]). It can be seen that the transformation of epoxy material from a liquid state to a solid state is related with an increase of free vibration frequency (i.e. the shear modulus of the examine coating). Measurements carried out at higher temperatures show a shift of the obtained curves to the shorter times. In works [7, 13] it was shown that from this shift one can determine the activation energy of the observed curing reaction. Irrespective of a profound analysis of the data presented in Fig 7 one can state that the measured curves $f(t)$ allow determining the time necessary to obtain fully cured epoxy material.

A systematic study of adhesion coefficient for cured epoxy polymer coatings was carried out in [7]. The measurements of elastic properties of Hysol type coatings at room temperature were performed using vibrating reed technique. The studied coatings were deposited on alumina alloy substrate (EN AW-5251) with different preparation of the surface such as: Ac - acetone degreasing for 5 min, Gr - grinding with abrasive paper (grit 320) and 5 min acetone degreasing, and Et - etching in water solution of H_2SO_4 and $Na_2Cr_2O_7 \cdot 2H_2O$ according to [14]. Polymeric coatings deposited on such prepared substrates were cured at room temperature (i.e. 296 K) for 2200 min. Additional measurements were carried out for samples with Gr-type surface preparation and annealed at: 350 K/ 90 min, 370 K/40 min. Thickness of the examined coatings was about 100 μm .

For coatings prepared in such a way two tests have been carried out: i) using vibrating reed technique (clamped-free configuration, frequency c.a.100 Hz, strain amplitude of the order of 10^{-5}) the apparent Young's modulus $\gamma^2 E_f$ was measured and ii) using Instron machine the bond shear strength W of specially prepared joints was measured by applying the tensile lap-shear

strength tests. In this case the samples consist of two rectangular parts with Ac, Gr and Et surface preparation which were stuck together, pressed (the excess of the polymer was removed) and cured at the selected temperatures i.e. 296 K, 350 K and 370 K (for the same time as the samples used for the vibrating reed tests). Thicknesses of the prepared joints do not exceed 100 μm . The dimensions of the rectangular parts were 2 mm \times 25 mm \times 100 mm and the contact surface was 12 mm \times 25 mm. Such prepared samples were subjected to the tensile tests. The bond shear strength W was calculated according to [14, 15] using the equation $W=P/S$ where P and S stand for joint destroying force and joint surface area, respectively.

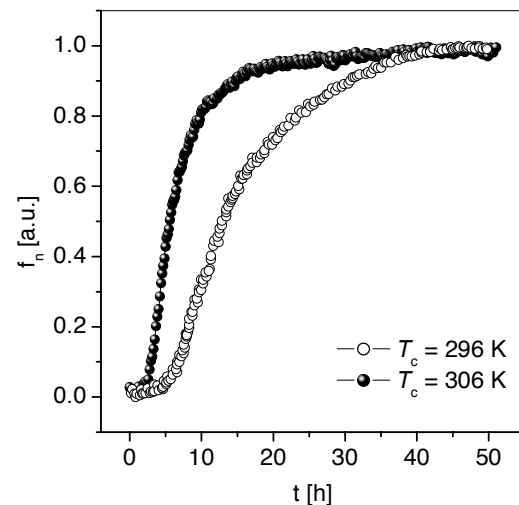

Fig. 7. Normalized frequency of free vibrations f_n versus curing time determined for epoxy resin (trademark Loctite Hysol 3423) using inverted torsion pendulum [7]

Fig. 8 shows the apparent Young's modulus $\gamma^2 E_f$ plotted versus the bond shear strength W (Instron test) for epoxy system coatings on aluminum-based substrate with different surface preparation. From Fig. 8 one can see that experimental points obtained by making use of different techniques correlate on one straight line passing through the origin. This means that the vibrating reed technique (non-destructive method of determination of elastic properties of coating materials) gives the same results as frequently used destructive tests performed by making use of Instron machine. Moreover the results from Fig. 8 also confirm that eq. (16) can be successfully applied in the examinations of elastic properties of polymer coating materials. Let notice that for the same curing temperature $T_C=296$ K the highest values of $\gamma^2 E_f$ were obtained for the epoxy resin coatings deposited on Et type. Taking into account coatings deposited on the same type of surface preparation (Gr) and cured at different temperatures one can state that the coating cured at $T_C=350$ K shows the highest value of the apparent Young's modulus. Note that curing at higher temperature $T_C=370$ K deteriorates elastic properties of the coating. This means that the presented method can be used in optimization of the substrate-coating binding quality.

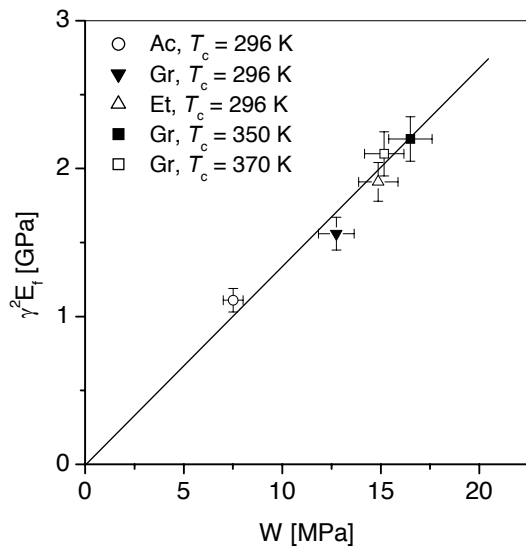

Fig. 8. Plot of $\gamma^2 E_f$ (vibrating reed technique) versus bond shear strength W (Instron test) for epoxy system coatings on aluminum-based substrate with different surface preparation. (Ac-acetone degreasing for 5 min, Gr-grinding with abrasive paper (grit 320) and 5 min acetone degreasing, Et-etching in water solution of H_2SO_4 and $Na_2Cr_2O_7 \cdot 2H_2O$, T_c -curing temperature) [7]

In many applications polymer materials are used in a form of relatively thin coatings deposited on a metallic substrate. This kind of possible application is mainly determined by such mechanical properties as Young's modulus, adhesion coefficient or critical shear strength. As it was already demonstrated the elastic properties of the coatings are always coupled with coating adhesion to the substrate.

Fig. 9a shows the relative adhesion coefficient γ_r determined for an oil-color (commercially available) coatings on carbon steel substrate with different contact surface preparation: i) applying a lubricant film known under commercial name Apiezon, ii) etching in 50% water solution of HCl (5 min.), iii) etching in 50% water solution of HCl and grinding with abrasive paper of grit 60 and iv) etching in 50% water solution of HCl (5 min.) and grinding with abrasive paper of grit 360. It can be seen that with increasing the abrasive paper grit the relative adhesion coefficient increases. Let notice that the total change of γ_r for the data from Fig. 9a is about 90%.

Fig. 9b shows similar results as presented in Fig. 9a obtained for the commercially available epoxy adhesive (known as trademark Distal) in a form of coating on carbon steel substrate with surface preparation: HCL etching (5 min), Gr-grinding with abrasive paper (grit 60, 120 and 360).

As a conclusion it has to be stressed that the results presented in Figs. 9a and 9b quantitatively describes the change of the adhesion coefficient with different preparation of the contact surface in the coating-substrate system. Such information should have important meaning in optimization of coating deposition technological process.

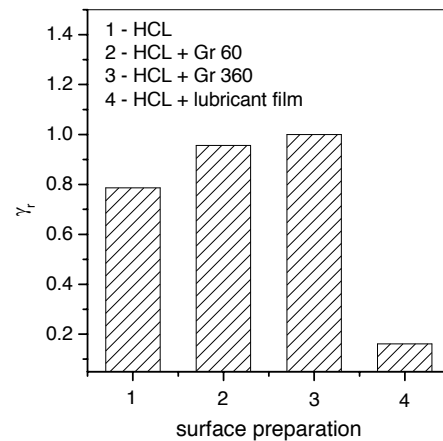

Fig. 9a. Relative adhesion coefficient γ_r determined for commercially available oil-color deposited in a form of coating on carbon steel substrate with different surface preparation: HCL etching (5 min.), Gr-grinding with abrasive paper (grit 60 and 360)

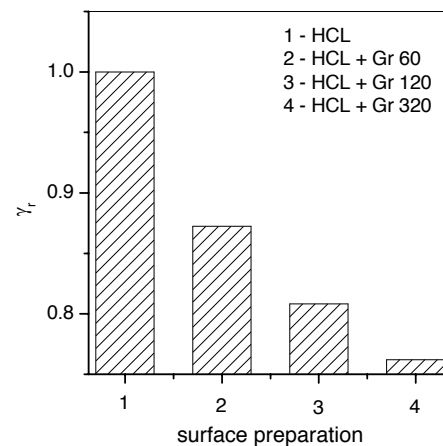

Fig. 9b. Relative adhesion coefficient γ_r determined for commercially available epoxy adhesive (trademark Distal) deposited in a form of coating on carbon steel substrate with different surface preparation: HCL etching (5 min), Gr-grinding with abrasive paper (grit 60, 120 and 360)

4.3. Composite coatings

Nickel-molybdenum composite coatings can be obtained using electroplating method according to the procedure described in [16]. Such coatings deposited on metallic substrate are known as special materials design for electrochemistry applications. It is characteristic that the presence of Mo particles embedded into Ni matrix modifies the morphology of the coating i.e. creates porous structure with strongly developed surface. From electrochemical point of view such a behavior is very favorable because it enhances electrochemical activity of the coating, and causes that

such composite coatings are of great interest as electrode materials especially for hydrogen evolution [17, 18]. However it is known that porous structure of the composite coating significantly deteriorates its elastic properties and in consequence hinders the applications. However, such materials are very interesting not only on account of its application but also from scientific point of view. In the work [16] elastic properties of Ni and Ni+Mo composite coatings deposited electrochemically on stainless steel substrate were investigated by applying vibrating reed technique. Morphology of the investigated coatings was presented in Figs. 10a and 10b (Scanning Kelvin Probe, M-370).

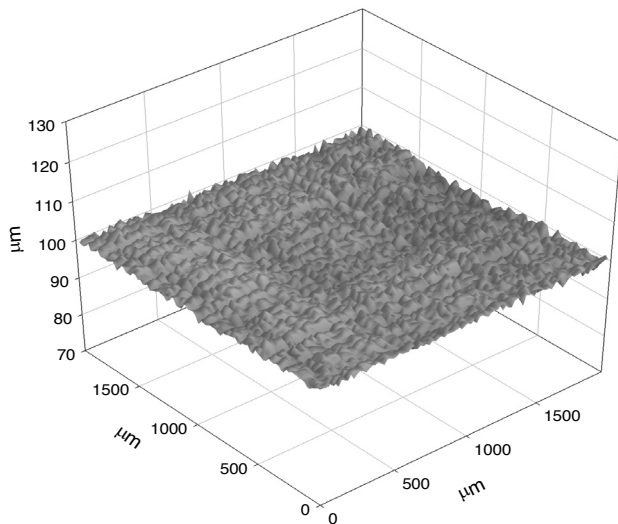

Fig. 10a. Morphology of Ni coating deposited on stainless steel substrate determined by Scanning Kelvin Probe technique

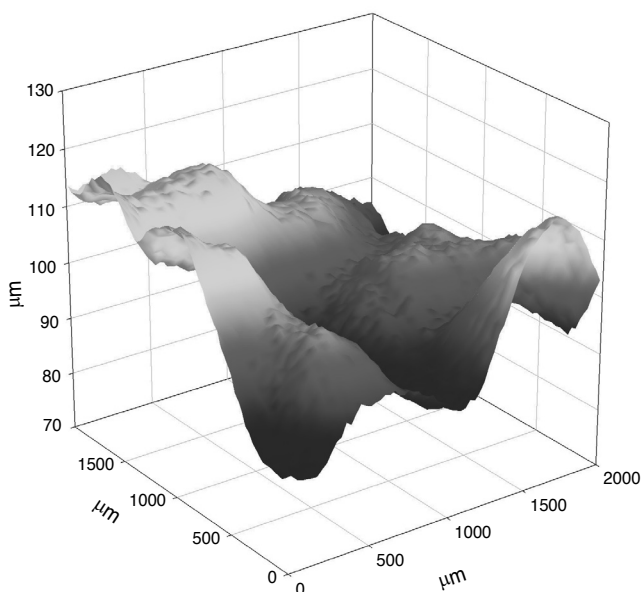

Fig. 10b. Morphology of Ni+Mo coating deposited on stainless steel substrate determined by Scanning Kelvin Probe technique

Fig. 11 shows Young's modulus of Ni+Mo composite coating with different content of Mo. In the data analysis it was assumed that the adhesion coefficient for Ni+Mo composite coating deposited on the stainless steel substrate is the same as for Ni coating. Microscopic observations of the cross section confirm that Mo powder particles practically have no contact with the substrate and change only the material modulus. The obtained result can be easily generalized i.e. adhesion of the composite coating to a given substrate is essentially the same as the adhesion of the main ingredient to the same substrate. This conclusion seems to be valid as long as the content of one ingredient of composite is dominant and allows determining the absolute value of E_f . From Fig. 11 it can be seen that E_f determined for Ni coating is more than three times higher than values E_f determined for Ni+Mo composite coating with 9 wt.% of Mo. Additionally, increase in Mo concentration (from 9 to 32 wt.%) results in decrease in E_f from 40 to 23 GPa.

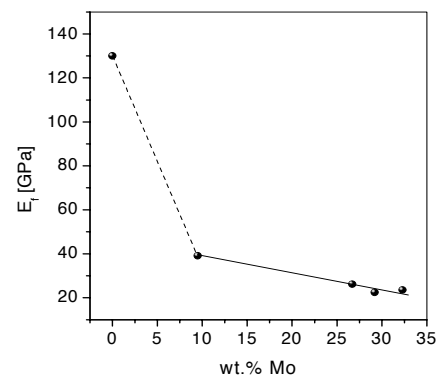

Fig. 11. Young's modulus of Ni+Mo composite coatings determined in room temperature versus concentration of Mo particles in Ni matrix [16]

In the paper [8] some polymeric composite coatings consisting of amine-epoxy resin and ferromagnetic (iron) powder with different grain size were carefully examined. Fig. 12 shows the apparent Young's modulus obtained for three different composite coatings (as received powder, 4 h milling and 8 h milling) plotted versus iron powder volume content. One can see that for each kind of composite coating the apparent Young's modulus strongly increases with increasing powder content showing saturation for 20 vol.% of iron. Note, for a coating free of iron powder $\gamma^2 E_f$ is found to be 1.3 GPa and for 40 vol.% of iron powder this value reaches about 8.0 GPa for the as received powder and about 8.8 GPa for the 8 h powder milling (25 vol.%). It is also evident that the observed increase depends on powder grain dimensions though the values obtained for the 8 h powder milling are only slightly higher than those obtained for 4 h powder milling. Such behavior was explained in [8] by assuming that a mean distance between iron grains for the same volume percentage of powder decreases with decreasing grain size. In addition, it was shown that similarly to Mo particles in Ni+Mo composite coatings the Fe particles do not have a direct contact with the substrate surface. So the adhesion of all studied coatings can be assumed to be the same. According to this assumption the

values in Fig. 12 represent the change of E_f with the concentration of Fe powder in the polymeric coating. However, in contrast to Ni+Mo composite the addition of metallic powder to the polymeric matrix results in an increase of E_f .

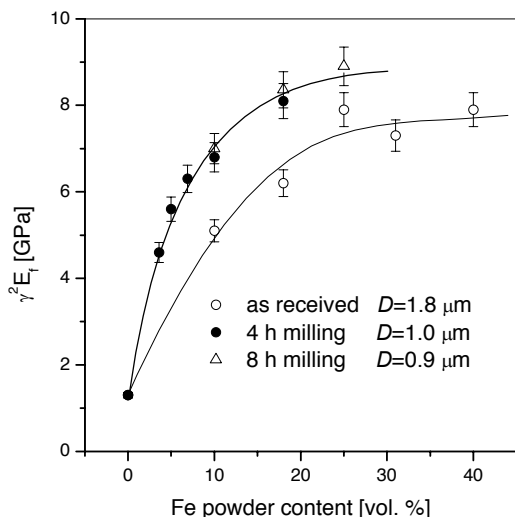

Fig. 12. Apparent Young's modulus $\gamma^2 E_f$ versus Fe powder content with different grain size determined for polymeric composite coatings [8]

5. Concluding remarks

The results gathered in this paper show that the proposed procedure of studying elastic properties of coating materials by making use of vibrating reed technique finds a lot of applications in material engineering. It was shown that measurements of free vibration frequency of sample consisting of a substrate and deposited coating, according to eq. (10), are a source of information on Young's modulus of coating and its adhesion to the substrate.

The application of the proposed approach to metallic polymeric and composite coatings allowed obtaining an important information about the change of both the elastic properties and the adhesion coefficient with a change of: coating thickness, measurement temperature, chemical composition of coating, contact surface preparation or in the case of epoxy resin coatings also with a change of curing time or curing temperature.

The results shown in this work indicate that from technological point of view the most important quantity describing elastic properties of coatings is the apparent Young's modulus connected directly to the resistance of the coating to the elastic deformation and its adhesion to the substrate.

Acknowledgements

This work was supported by the Polish Ministry of Science and Higher Education under grant No. N507 317336.

References

- [1] M. Kubisztal, Elastic properties of the coatings on metallic substrate, Silesian University PhD work, Katowice, 2009 (in Polish).
- [2] A.S. Nowick, B.S. Berry, Anelastic Relaxation in Crystalline Solids, Academic Press, New York, 1972.
- [3] B.S. Berry, W.C. Pritchett, Vibrating reed internal friction apparatus for films and foils, IBM Journal of Research and Development 19 (1975) 334-343.
- [4] B.S. Berry, in: D. Gupta, P.S. Ho (Eds.), Diffusion Phenomena in Thin Films and Microelectronic Materials, Noyes, Park Ridge, New York, 1988, 73-141.
- [5] Q. Su, S.Z. Hua, M. Wuttig, Nondestructive dynamic evaluation of thin NiTi film adhesion, Journal of Adhesion Science and Technology 8 (1994) 625-633.
- [6] M. Wuttig, C.M. Su, Dynamic mechanical properties of thin-layer materials, Proceedings of the Damping of Multiphase Inorganic Materials Symposium, ASM Materials Week, Chicago, Illinois, USA, 1992, 159-163.
- [7] M. Kubisztal, G. Haneczok, A. Chrobak, B. Rams, D. Miara, J. Rasek, Elastic properties of epoxy system coatings on aluminum substrate, Surface and Coatings Technology 204 (2009) 120-124.
- [8] A. Chrobak, M. Kubisztal, J. Kubisztal, G. Haneczok, Adhesion coefficient and elastic properties of composite coatings on metallic substrate, Surface and Coatings Technology 204 (2010) 2077-2080.
- [9] M. Weller, in: R. Schaller, G. Fantozzi, G. Gremaud (Eds.), Mechanical Spectroscopy Q-1 2001, vol. 366-368, TTP, Utikon-Zuerich, 2001, 549-559.
- [10] M. Kubisztal, G. Haneczok, A. Chrobak, J. Kubisztal, A. Budniok, Patent application P383058, 2007 (in Polish).
- [11] M. Kubisztal, J. Kubisztal, A. Chrobak, G. Haneczok, Young's modulus and adhesion coefficient of amorphous Ni-P coatings on a metal substrate, Journal of Adhesion Science Technology 21/11 (2007) 1009-1019.
- [12] R.C. Agarwala, V. Agarwala, Electroless alloy/composite coatings: A review, Sadhana 28 (2003) 475-493.
- [13] M. Kubisztal, G. Haneczok, A. Chrobak, A. Kubik, J. Rasek, Study of epoxy resin curing process by applying internal friction technique, Materials Science and Engineering A 521(2009) 283-286.
- [14] Polish Standard PN-ISO 4588, 1999.
- [15] Polish Standard PN-EN 1465, 2003.
- [16] M. Kubisztal, J. Kubisztal, A. Chrobak, G. Haneczok, A. Budniok, J. Rasek, Elastic properties of Ni and Ni+Mo coatings electrodeposited on stainless steel substrate, Surface and Coatings Technology 202 (2008) 2292-2296.
- [17] J. Kubisztal, A. Budniok, A. Lasia, Study of the hydrogen evolution reaction on nickel-based composite coatings containing molybdenum powder, International Journal of Hydrogen Energy 32 (2007) 1211-1218.
- [18] J. Kubisztal, A. Budniok, Study of the oxygen evolution reaction on nickel-based composite coatings in alkaline media, International Journal of Hydrogen Energy 33 (2008) 4488-4494.