

An intelligent approach to high quantity automated machining

M. Tolouei-Rad*

School of Engineering, Edith Cowan University, Perth, Australia

* Corresponding author: E-mail address: m.rad@ecu.edu.au

Received 05.06.2011; published in revised form 01.08.2011

Analysis and modelling

ABSTRACT

Purpose: To investigate the possibility of application of knowledge-based expert systems to facilitate the task of techno-economical feasibility analysis of utilization of special purpose machines for high quantity production tasks. Also, to study the possibility of assisting special purpose machine designers in applying knowledge-based expert systems in the design task in order to reduce required machine design time, improve machine design efficiency, and eliminate possible human errors.

Design/methodology/approach: Development of a knowledge-based expert system has been proposed to help decide where to utilize special purpose machines to accomplish the production task. The knowledge-based expert system consists of a rule-base which contains qualitative human knowledge and expertise in the form of if-then rules; and a database which contains qualitative information of machining operations, and characteristics of standardized special purpose machine components.

Findings: A case study has been presented where an analysis has been made on the basis of techno-economical considerations for a typical part with three machining operations to be produced in large quantities. It has been concluded that for the given production task, special purpose machines would result in a significant 59% reduction of costs compared to CNC machines, and 95.5% compared to traditional machines. The proposed methodology also reduces the time and effort needed for decision making on utilization of special purpose machines and determination of machine layout. In addition, it minimizes the level of expertise required to perform these functions and eliminates possible human errors.

Research limitations/implications: The current system focuses on drilling and drilling-related operations which cover about 60% of all machining operations. More work is needed to cover other machining operations including milling. Also the KBES developed currently works on a standalone basis. Work is in progress to integrate it with a 3D CAD modelling system. Upon completion the information could be directly extracted from the CAD system, eliminating the need for manual data input by the user.

Originality/value: In spite of a large number of publications on machine tool design in the literature, publications on special purpose machines are very limited. The method of techno-economical analysis presented here for utilization of special purpose machines in comparison with other production alternatives is of great value to manufacturing engineers and specialists. Also the methodology presented for machine design and implementation is highly valued by machine tool designers and manufacturers.

Keywords: Drilling; Expert systems; Machining; Special purpose machines

Reference to this paper should be given in the following way:

M. Tolouei-Rad, An intelligent approach to high quantity automated machining, Journal of Achievements in Materials and Manufacturing Engineering 47/2 (2011) 195-204.

1. Introduction

With availability of many machining processes capable of performing drilling operations sometimes it is difficult to decide which process would result in a higher profit or a lower unit cost for a given task. Due to increasing global competition, manufacturing industries are now more concerned with their productivity and are more sensitive than ever to their investments with respect to flexibility and efficiency of production equipment [1, 2]. Researchers [3] believe that increasing the quality of production and reducing cost and time of production are very important factors in achieving higher productivity. Achieving this goal requires reconsidering current production methods that could lead to introduction of new production techniques and more advanced technologies.

In traditional drilling processes a sharp cutting tool with multiple cutting edges is used to cut a round hole in the workpiece material. In non-traditional drilling processes various forms of energy other than sharp cutting tools or abrasive particles are used to remove the material. The energy forms include mechanical, electrochemical, thermal and chemical [4]. Generally non-traditional processes incorporate high capital and operating costs. Therefore, when machining economy is of concern manufacturing companies focus on traditional processes. Even within this category, a machining specialist has the choice of using conventional drilling machines, CNC machines, and special purpose machines (SPMs). According to the literature [5] when production quantity and variety are low, universal machine tools give the best result. When various components should be produced, CNC is the best option. For the condition of high production quantity with low variety, SPM gives the highest productivity and is considered as the most economic production method. Accordingly, Tolouei-Rad and Zolfaghari [6] believe that SPMs are superior to computer numerical control (CNC) machines for producing large quantities of similar parts; however, most manufacturers still rely on well-known CNCs for large volume production tasks. This is mainly attributable to the fact that both SPMs and CNCs incorporate high capital costs; SPMs are more productive and CNCs are more flexible. When the part in production is no longer in demand due to frequent market changes, SPMs become idle while CNCs can be easily reprogrammed for producing other parts. The concluding statement could be drawn when modular SPMs are utilized.

The field of machine tools for generating singular products is well documented; however, the area of specialist machines for dedicated tasks has received less attention [7]. This is particularly true for modular SPMs that are a new addition to the family of SPMs [8]. Proper design and utilization of these machines depend upon knowledge, experience, and creativity of SPM designers and machining specialists. Because of modularity in structure, these machines can be applied to the production of a range of parts upon modification. The specific advantages of utilization of this technology have placed them in a superior position in comparison with other machine tools. These advantages mass production of parts in shorter time, high accuracy of products, uniformity and repeatability of production, elimination of some quality control steps, simultaneous machining of a number of parts, and reduced labour and overhead costs.

The modular principle is very popular in the design of many products such as automobile, home appliances, information devices, industrial equipment, etc. This trend can be considered as one of the great contributions of modular design of machine tools to those working in other industries [9]. This article focuses on modular SPMs and for simplicity in the rest of this article modular SPM is referred to as SPM. SPMs do not have a rigid bulky configuration and the machine can be rapidly set up by putting together a number of machining and sliding units, chassis, and other equipment. This is achieved by making use of various types of mechanical fasteners. Once the part in production is no longer in demand, SPMs can be dis-assembled and re-assembled in a different configuration to be used for producing other parts. Utilization of SPMs eliminates the risk of high capital loss while providing higher productivity for large production quantities. Properly utilization of SPMs could have a significant impact on the productivity of manufacturing industries; and production improvements of up to 25:1 have been reported [10]. However, the extent of the application of SPM technology in industry is not proportional to its potential impact on productivity improvement. This is mainly attributed to the fact that machining specialists find it difficult to decide when to use SPMs. Making the right decision is a time-consuming task and requires a techno-economical analysis to be performed by expert people. This article addresses a methodology developed to tackle this vital problem. It investigates the possibility and effectiveness of employing artificial intelligent techniques to assist manufacturing firms in feasibility analysis of utilizing SPMs in order to improve productivity. It is important to note that in spite of many publications on production technologies and machine tool design; publications on design and utilization of SPMs are very limited.

Intelligent systems have been extensively used to effectively tackle some real engineering problems in the last three decades. Yet researchers explore new application areas for utilization of various artificial intelligence techniques. Knowledge-based expert systems (KBESs) have proven to be effective for decision making when dealing with qualitative information, hard to capture in a computer program. Accordingly, in the current work a KBES has been developed and used for utilization feasibility analysis of SPMs in different manufacturing settings.

2. SPM technology

Groover [5] has defined the term "production automation" as the application of electrical, electronic, mechanical, hydraulic and pneumatic systems for rapid and quality productions in large volumes. Automated production techniques are widely used in manufacturing industries for dealing with issues such as high cost of labour, shortage of skilled people, low interest of labour to work in production firms, safety, high cost of raw materials, improved quality, uniformity in the quality of products, low inventory, customers satisfaction, and performing difficult operations. Figure 1 shows a SPM as an example of utilization of automated production techniques in manufacturing. This machine is used for performing drilling and tapping operations on the workpiece from various directions at a single setup. In the figure machining units are in blue and the chassis in white. Figure 2 schematically illustrates a workpiece with holes in various positions

and possible positioning of machining units to perform required drilling operations.

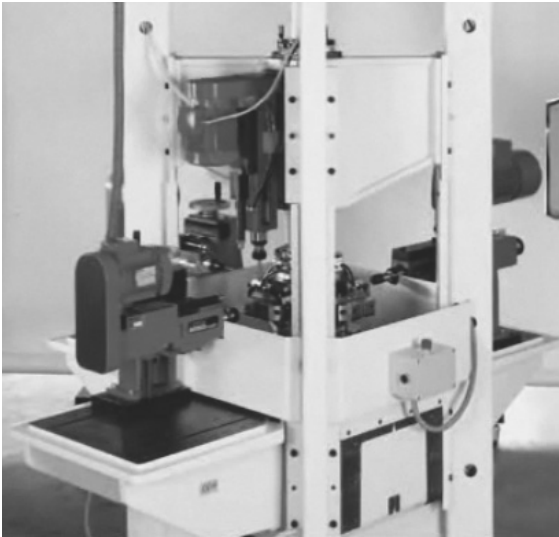

Fig. 1. A typical SPM for performing drilling and tapping operations [11]

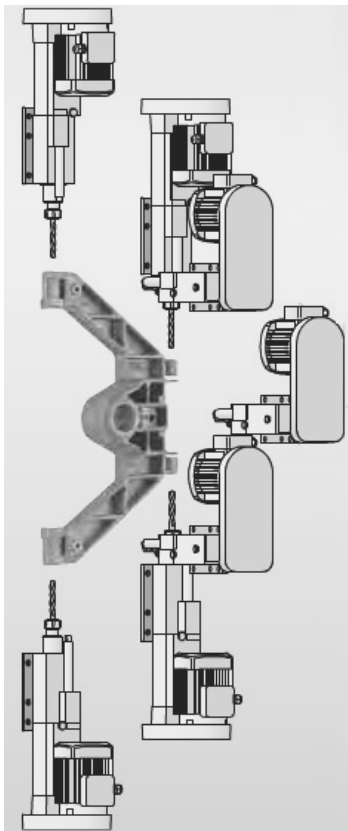

Fig. 2. Positioning of machining units to perform required drilling operations on a typical workpiece [11]

Generally SPMs lack the high rigidity found in conventional and CNC machines. Consequently, majority of these machines are used for performing drilling and drilling-related operations such as tapping, reaming, counterboring and countersinking on machinable materials where the magnitude of machining forces is relatively low. This eliminates excessive vibrations of the machine tool due to high cutting forces. However, it should be noted that SPMs are also capable of performing milling and some other operations that would result in high cutting forces. In such cases there is a need for stronger chassis, stronger machining and sliding units, and use of special accessories in order to eliminate vibrations when possible.

2.1. Machining and sliding units

The units used in SPMs can be divided into two main groups: machining and sliding. A machining unit is equipped with an electro-motor that revolves the spindle by means of pulley and belt systems in order to rotate the cutting tool. Like other machine tools, the connection of cutting tools to the machining unit is accomplished by standard tool holders. Machining units are of three types: telescopic, power, and CNC. Telescopic or quill units are used for light drilling and drilling-related operations as they also provide the spindle with a linear feed motion necessary for penetration of the cutting tool into the workpiece. Both the linear and the rotational motions necessary for performing operation are provided simultaneously. Power units are used for drilling, drilling related, and milling operations where large cutting forces exist. Unlike telescopic units, power units lack the linear feed motion due to presence of significantly larger cutting forces that may cause deflection in rotating spindle. Consequently, these units are mounted on sliding units providing them with necessary linear feed motion. Figure 3 shows a telescopic or quill unit with spindle in and out configurations.



Fig. 3. Telescopic or quill unit with spindle in and out configurations [11]

Sliding units may carry machining units and provide necessary feed motion of the tool by means of hydraulic/pneumatic actuators, or servomotors. Adjusting the course of motion is provided by use of micro-switches or mechanical limits. Figure 4 shows a sliding unit with hydraulic actuator and a mechanical course adjustment mechanism.

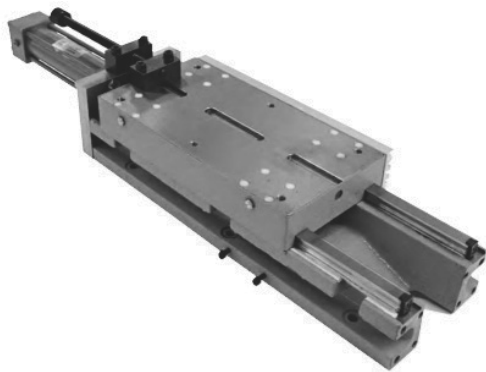

Fig. 4. Sliding unit with hydraulic actuator [11]

2.2. Accessories

There exist special stands, adjustable bases, and supports used for positioning and supporting basic machine components. These are also used for preventing or reducing vibrations at the time of machining. Figure 5 shows some of the assembly equipment used to accurately position and support machining units in any position and at any angle.

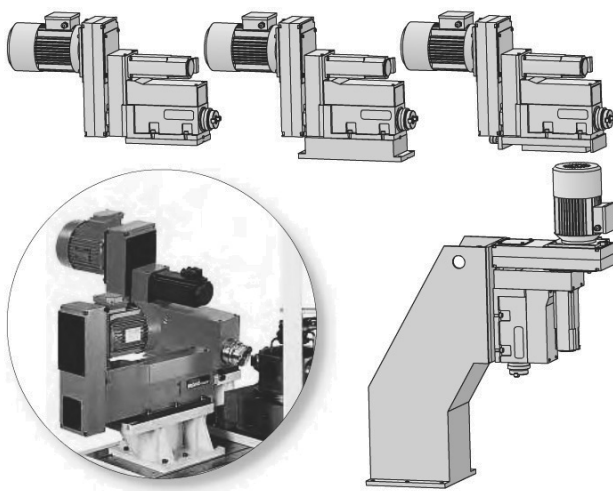

Fig. 5. Assembly equipment for positioning machining units [11]

Multi-drill heads provide the possibility of drilling many holes on the same plane simultaneously; thus, reducing machining time significantly. Multi-drill heads are divided into fixed and adjustable types. In fixed multi-drill heads the position of tools are fixed, but in adjustable ones the position of the tools could be adjusted as needed. Figure 6 shows two adjustable multi-drill heads.



Fig. 6. Adjustable multi-drill heads with cutting tools and holders [10]

2.3. Table and chassis

The table and chassis of the machine are very important considerations in SPMs. Based on technical considerations and machining properties of the workpiece material, the table and chassis are properly designed or selected from the standardized SPM chassis. Due to high machining forces resulting from machining operations the machine table and chassis should be sufficiently rigid to avoid vibrations. It is also very important to consider appropriate coolant and chip removal mechanisms in design of machine table and chassis.

3. Design and manufacturing

Because production process is systematic, planning for design and manufacturing has an effective influence on the success of any project [12].

3.1. Techno-economical analysis

As the cost of SPM design and manufacturing is relatively high, critical technical and economic justification of utilization of these machines should be made before any attempt to design and manufacture them. This includes an analysis of machinability of the workpiece, and a comparison of the production costs with other production alternatives considering production volume and machine amortisation period. For technical feasibility analysis a number of questions will be asked and the user needs to answer these questions interactively. These questions investigate quality of workpiece material and its physical and geometrical characteristics to determine whether or not it can be machined with SPMs. Upon completion of technical feasibility analysis, an economical feasibility analysis is performed. To do so a detailed computation is needed in order to determine the cost of machining a unit of product using SPM. Then the same computation is repeated for traditional and CNC machines in order to achieve a unit cost comparison for different methods, and to find the one that results in a lower cost. For determination of unit cost so many

factors are taken into consideration including machining time, production volume, machine cost, cutting tool cost, labour cost, overhead costs, depreciation cost, interest rate, etc. It is noteworthy that sometimes it is necessary to repeat the economic analysis before the final approval of SPM design. This happens when more accurate information on the cost of SPM and required accessories is available.

3.2. Machining sequence planning

Properly determination of machining sequence is a key point in successful SPM utilization. A poor machining sequence plan leads to lower quality of production and/or increased machining times and consequently higher production costs. Often it is possible to combine and perform a number of operations in a single setup lowering machining times and costs while also improving production quality. Indeed machining sequence planning determines the overall configuration of the machine and required machining units and accessories.

3.3. Cutting conditions

Properly selection of cutting tools and cutting conditions such as cutting speed, feed, and depth of cut is of great importance in the success of any machining operation. When SPM is in use, due to the stability requirements of the production process in order to produce high quantities of the product, appropriate cutting tools and cutting conditions should be employed. As frequent tool changes influence the productivity of the machine tool, it is suggested to employ long lasting hard material cutting tools made from tungsten carbides and ceramics for high production rates. These tool materials provide longer tool lives and higher production rates. Other important considerations in the selection of cutting tools are the shape and geometry of the tool. Cutting tools are generally divided into standard and special groups. By use of specially designed cutting tools sometimes it is possible to combine different machining operations in a single operation.

3.4. Part setup and clamping

Machining jigs and fixtures are frequently used to increase the speed and quality of production and to reduce production times and required skill level of machinists. Uniformity of production due to use of jigs and fixtures has an important effect on production quality. Accordingly, properly design and application of jigs and fixtures is very important in SPM utilization. Fixtures used in SPMs are complex as normally a number of machining operations are performed in a single part setup. Fixtures should be designed such that (a) there is adequate tool access to the workpiece in all work stations; (b) the part is easily, quickly, and accurately positioned inside the fixture, and removed from it, and (c) the fixture is rigid enough to withstand large cutting forces applied by multiple cutting tools working on the part simultaneously. In locating the part in the fixture, the most difficult and accurate operation should be considered first in order to achieve the best result. Because there are different machining operations, locating surfaces need

to be machined accurately before the workpiece is placed in the fixture. Appropriate measures should be taken for free flow of coolant and chip removal from the fixture.

3.5. Selection of machining and sliding units

As described in the previous sections, machining and sliding units are the most important components of SPMs that make the cutting tool capable of rotational and linear motions necessary for cutting. Consequently, the selection of machining units, sliding units and accessories should be accomplished such that following three conditions are met.

- 1) Previously determined cutting tools are capable of performing all rotational and linear motions necessary for performing corresponding machining operations.
- 2) Proper cutting conditions such as spindle speed, feed, and depth of cut are provided.
- 3) Required machining power is provided.

It is important to note that selection of machining and sliding units should always be accomplished after selection of cutting tools and cutting conditions. This is due to the fact that cutting tools' geometry and cutting conditions dictate required powers, velocities, and motions of machining and sliding units.

3.6. Machine layout

Generally there are two layouts for SPMs; single-station and multi-station. In the former method the workpiece is held in a fixed position where machining and sliding units are positioned around it such that they can process the part from different directions. The part is machined by a single machining unit or by multiple machining units. In the case of multiple machining units they may process the part simultaneously or in sequence depending on the geometry of the workpiece and machining features. This layout is shown in Figure 7a. In latter method the workpiece is transferred from one station to another until it is processed in all stations. The number of machining stations varies from two to twelve. Transferring workpiece between stations is performed by rotational or linear motions. The rotational motion is provided by indexing tables and the linear motion can be performed by use of sliding units or other methods. Figures 7b to 7e illustrate different multi-station layouts. The layout of the machine and positioning all the machining and sliding units, the number of stations in case of multi-station processing, and workpiece transferring method between stations are decided by machine designers considering technical and productive measures. In general a higher production rate is achieved in the multi-station method because of simultaneous machining of several workpieces in multiple machining stations. Figure 8 shows a typical in-line SPM as represented in Figure 7e. As can be seen in the figure, this machine is equipped with flexible drive shafts for transmission of power from motor to rotating spindle.

3.7. Control system

Before designing the control system, the unit motion diagrams representing reciprocating motions of all units should be prepared.

These diagrams explicitly represent speed and magnitude of motion of each unit, exact start/stop times, and its position at any time. As described earlier, the motion of units is often provided by hydraulic and pneumatic cylinders, or servo-motors. Start and stop signals of motion are usually issued by a PLC that is programmed based on the unit motion diagrams.

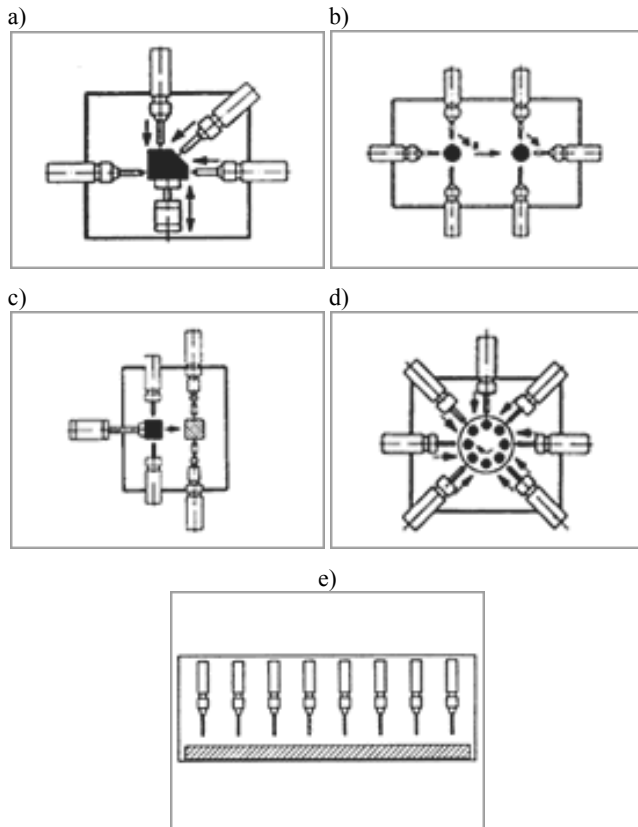

Fig. 7. SPM layouts for a) single-station, b) special application, c) transfer machine, d) rotary machine, e) in-line drilling [11]



Fig. 8. An in-line SPM for drilling with flexible drive shafts [11]

3.8. Approval

Upon completion of preceding steps, it is necessary that all design steps be controlled and inspected by experienced SPM specialists to correct possible errors before sending the machine design to the workshop for manufacturing. These points deserve special consideration at this stage: a) control system and PLC programming, b) types and specifications of machining and sliding units, c) motion diagrams, d) hydraulic and pneumatic systems and servo-systems, e) performance of the machine, and g) possible collision of the moving parts with other moving or fixed parts. As mentioned before, sometimes it becomes necessary to repeat economic considerations of the feasibility of SPM utilization before the machine is built. This is attributable to the fact that initial economic analysis has been made based on the initial estimation. However, when detailed machine design is available a more precise machine cost becomes available that could be different.

3.9. Manufacturing and testing

Chassis and table of the machine should be made and assembled considering technical issues. These parts should be sufficiently rigid and equipped with special dampers in order to minimize vibrations resulting from the operation of cutting tools. Generally, thick steel plates and cast iron are used for machine table. Cast irons have good damping character, and therefore, are used for making the machine table to reduce vibrations. Chip removal could be a huge problem in SPMs that cannot be appreciated before the machine is made. The volume of chips produced in SPMs is high and this could reduce effective machining time by half or even less when a proper chip removal mechanism is not considered. In addition, a properly designed coolant system should be used to enhance the lives of cutting tools as frequent tool changes increase machining costs. Then, based on detailed engineering drawings, installation of stands, supports, machining units, sliding units, indexing table and coolant system are performed. Installation of hydraulic and pneumatic systems, wiring, electric power supply to electro-motors, and finally, the control systems are all performed at this stage.

Upon completion of previous steps, machine performance is measured considering required product quality and production volume. Possible issues at this stage are detected and resolved to bring the machine to a more productive state. Producing a reasonable number of quality products is necessary before actual production begins.

4. Knowledge-based expert system (KBES)

A KBES has been developed to perform the analysis of SPM utilization and determination of machine layout and its basic components. Its development has been described in this Section.

4.1. Knowledge acquisition of the process

The most common obstacle in utilization of SPMs in manufacturing industries is inadequate knowledge of manufacturing engineers and machining specialists with this technology, and the lack of a solid foundation for technical and economic feasibility analysis. This is not an easy task and requires engagement of qualified personnel with reasonable expertise and experience in this field. One needs to do a lot of computations and use various handbooks and assumptions in order to accomplish this task. In recent years artificial intelligence techniques have proven to be capable of restoring human's logic and expertise and efficiently applying this expertise to tackle complicated engineering problems. For example, KBESs have been used to restore human's logic and expertise and efficiently applying this expertise to tackle complicated engineering problems including product design [13] and process planning [14]. Accordingly, a KBES has been developed in order to capture the knowledge of SPM specialists in a computer program, and integrate it with a large amount of machining and tooling data restored in the database. This allows less experienced people to use the system developed in order to perform a detailed and accurate analysis of SPM utilization for production tasks. A rule-base has been developed that restores knowledge in the rule-base in the form of *if-then* rules.

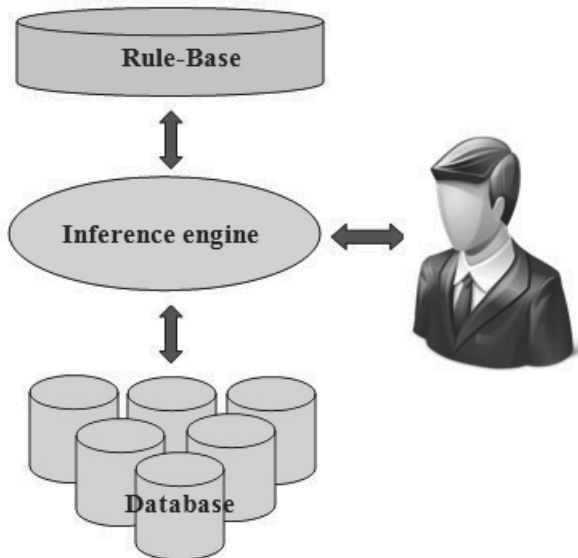

Fig. 9. Architecture of KBES

A large number of expertise rules have been developed in order to restore qualitative information in the rule-base as shown in Figure 9. One group of rules is specific to determination of workpiece setup such that there is tool access to all machining features in a single setup if possible. Another group of rules determine proper clamping method such that workpiece is securely held in place during machining. A group of rules determine the number of machining stations such that the total number of stations is kept minimal. Determination of required cutting tools and cutting

conditions, and required machine power are performed by other groups of rules. Some rules are developed for selection of machining units, sliding units, chassis, and accessories such as multi-drill heads, angle heads, etc. As can be seen in Figure 9, the KBES developed in this work is also equipped with a database. It contains quantitative information of available cutting tools and corresponding cutting conditions extracted from handbooks and other resources; and machining units and accessories extracted from the catalogues [10].

The KBES developed is capable of integrating qualitative information of the rule-base with quantitative data of the database. It uses forward chaining approach for firing the rules in the rule-base and to achieve the goal. Forward chaining starts with the data available (for example the plane of holes, size of holes, and centre-to centre distance between holes) and uses the inference rules to extract more data until a desired goal (for example the possibility of using multi-drill head) is reached. An inference engine searches the inference rules until it finds one in which the "if" clause is known to be true. It then concludes the "then" clause and adds this information to its data. It continues to do this until a "goal" is reached. The system stores input and output information of the processed workpieces in the database for future use. Therefore, it adds to the extent of its knowledge.

To determine the feasibility of utilization of SPM for a new workpiece, the inference engine first searches the database to find out whether it has been processed before. If so, it uses previously restored information. If not processed before then the inference engine searches for similar workpieces. When a similar workpiece is found then the system provides user with possibility of interactive modification if necessary. When a similar workpiece is not found then the system performs a full processing.

5. Case study

Figure 10 shows a rotational part 50 mm in diameter and 75 mm in length. As shown in the Figure this part has three machining features: counterboring, drilling, and tapping. The workpiece material is low carbon steel and it has not been subjected to heat treatment processes before. The annual production quantity is 1,500,000 and production will be running for five years. Manufacturer of this part faces three options for production: traditional machines, CNC Chiron machining centre, and SPM. As the part size is small, on the CNC machining centre it is possible to use a pallet carrying 50 parts. Once the pallet is loaded the machine begins processing 50 parts in one setup. Once processing of all 50 parts is completed the pallet will be exchanged with another one that is already loaded with 50 new parts ready for processing. This would significantly reduce machine idle time for loading and unloading.

Table 1 compares the times required for performing machining operations on the traditional lathe, CNC Chiron machining centre, and SPM. Total time of machining on traditional lathe and CNC machine are equal to the sum of cutting times plus non-cutting times that include tool changing between processes, loading/unloading, and free movements of cutting tool. A multi-station SPM will be used to machine this part with an indexing table with four stations, one for loading/unloading and three for processing. This makes it possible to perform all machining operations

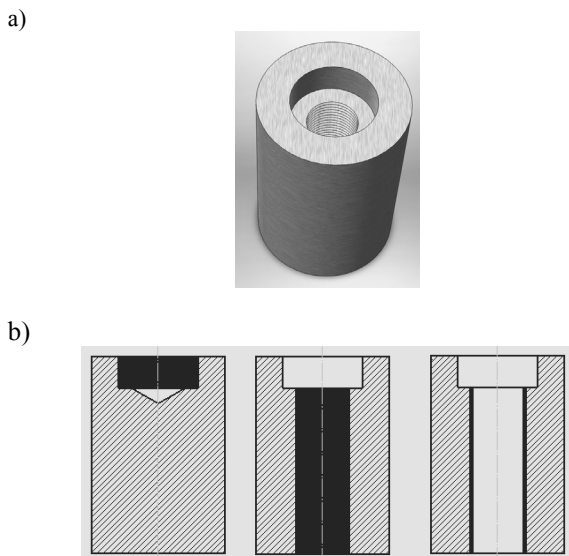

Fig. 10. a) Part with three machining features, b) operations from left to right: counterboring, drilling, and tapping

Table 1.
Comparison of machining times for traditional lathe, CNC, and SPM

	<i>Lathe</i>	<i>CNC</i>	<i>SPM</i>
	Time, sec	Time, sec	Time, sec
Counterboring time	5.0	3.0	3.0
Drilling time	8.0	4.0	4.0
Tapping time	10.0	5.0	5.0
Cutting time	23.0	12.0	5.6¹
Tool changing per part	6.0	0.12 ²	
Free tool traveling per part	6.0	0.6 ³	
Indexing time per part			1.2
Loading/unloading	15.0	2.40 ⁴	5.0 ⁵
Non-cutting time	27.0	3.12	1.2
Total time per part	50.0	15.12	6.8
Parts per hour	72	238.10	529.41

- 1: On the SPM the longest operation time determines the time required for each operation
- 2: Tool changing time for the CNC machine is 3 times of 2 seconds each for 50 pieces (0.12 sec/part)
- 3: Free tool traveling for the CNC machine is 30 seconds for 50 pieces (0.6 sec/part)
- 4: Loading/unloading time of one pallet carrying 50 pieces is 2 minutes (2.4 sec/part)
- 5: Loading/unloading on the SPM will be performed by an automated system and at the same time machining is in progress in other stations

simultaneously, one process at each station. Machining units are arranged such that all of the operations can be performed at a single part setup. Accordingly, the total machining time for each part is equal to the longest time needed for a single operation, plus one indexing time. As represented in Table 1, the total time per part on traditional lathe is 50 seconds, on the CNC machine 15.12 seconds, and it is only 6.8 seconds for SPM. Therefore, SPM produces 529.41 parts/hour, a figure remarkably higher than 238.10 for the CNC machine, and significantly higher than 72 for the lathe.

Yet it is possible to overhead costs that would result in a unit cost of \$4.7423. In the case of CNC machine there is a need to use two machines in order to achieve the required output. This would reduce the unit cost to \$0.5211 that is significantly lower. Yet SPM would further decrease this figure. Due to high productivity of SPMs only one machine with a single operator is needed to achieve the required output. This decreases most cost components including labour and overhead costs. Consequently the cost per part is reduced to only \$0.2138. In other words the use of SPM results in a significant 59% reduction of unit cost in comparison with CNC, and an amazing 95.5% cost reduction is achieved when compared to traditional lathe multiply the output of the SPM when all machining stations are equipped with multi-drill heads.

Table 2 represents machining unit cost for all of the three methods and provides all cost components. When traditional lathe is used there is a need to use seven machines in order to achieve required annual output. This significantly increases labour and

6. Conclusions

Production quality and low production cost are essential for the success of manufacturers in today's competitive market. SPMs are very useful for producing large quantities of high quality products at low costs. These machines can also be altered to produce similar components when necessary. High accuracy, uniform quality, and large production quantities are important characteristics of SPMs. However, the inadequate knowledge of machining specialists with this technology has resulted in its low utilization in manufacturing firms. In this article a detailed discussion of SPMs, their capabilities and accessories have been described. It also explained the development of a knowledge based expert system to assist SPM users in deciding whether or not to make use of SPMs. An analysis was made on the basis of technical and economical considerations. The case study presented clarifies the method of analysis between three methods for producing a typical part. After a detailed discussion and extensive computations it has been concluded that for the given production task SPM would result in a significant 59% reduction of costs when compared to CNC, and an unbelievable 95.5% cost reduction is achieved when compared to traditional lathe. The system described in this work significantly reduces the time and effort needed for decision making on utilization of SPMs and determination of machine layout. In addition, the system developed minimizes the level of expertise required to perform the analysis and eliminates possible human errors.

The current system focuses on drilling and drilling-related operations. More work is needed to cover other machining operations including milling. Also the KBES developed currently works on a standalone basis. Work is in progress to integrate it with a 3D CAD modelling system. The information could be directly extracted from the CAD system, eliminating the need for manual data input by user. A database of standard 3D components of SPM including machining and sliding units, accessories, clamps, and so on is being constructed on Solidworks software platform. This would assist SPM designers in the design task, and would help standardization of SPM designs that is of great importance to industries.

Table 2.
 Machining costs for traditional lathe, CNC, and SPM

		<i>Lathe</i>	<i>CNC</i>	<i>SPM</i>
<i>Production data</i>				
Parts required per year (D)		1,500,000	1,500,000	1,500,000
Production cycle (t)		5 years	5 years	5 years
Interest rate (r)		6%	6%	6%
Max. working hours per year (H)		3,600	3,600	3,600
<i>Machine tool data</i>				
Parts per hour (p)		72	238.10	529.41
Machine availability (a)		90%	95%	90%
Effective parts per hour (E)	$E = p \times a$	64.8	226.2	476.47
Working hours per year (h)	$h = D/E$	23148.15	6,637.17	3,148.15
Machines required (M)	$M = h/H$	6.43 \Rightarrow 7	1.84 \Rightarrow 2	0.87 \Rightarrow 1
<i>Wage costs</i>				
Wage rate (w)		\$45/h	\$45/h	\$45/h
Machinists required (R)		7	2	1
Wage per hour (W)	$W = w \times R$	\$315	\$90	\$45
Wage cost per part (C^w)	$C^w = W/E$	\$4.4811	\$0.3979	\$0.0944
<i>Cutting tool consumption</i>				
Tool cost per process (T)		\$0.0168	\$0.0168	\$0.0168
Number of processes per part (n)		3	3	3
Cutting tool cost per part (C^t)	$C^t = n \times T$	\$0.0504	\$0.0504	\$0.0504
<i>Electricity consumption costs</i>				
Electricity cost per kWh (k)		\$0.15	\$0.15	\$0.15
Machine electricity consumption (e)		9 kW	11 kW	36 kW
Total consumption (d)	$d = e \times R$	63 kW	22 kW	36 kW
Electricity cost per h (c)	$c = k \times d$	\$9.45	\$3.30	\$5.40
Electricity cost per part (C^e)	$C^e = c / E$	\$0.1456	\$0.0146	\$0.0113
<i>Machine depreciation costs</i>				
Machine investment cost per unit (u)		\$35,900	\$124,800	\$264,678
Total machine investment cost (U)	$U = M \times u$	\$251,300	\$249,600	\$264,678
Machine depreciation cost per year (f)	$f = U/t$	\$50,260	\$49,920	\$52,935.60
Depreciation cost/part (C^m)	$C^m = f/D$	\$0.0335	\$0.0333	\$0.0353
<i>Interest costs</i>				
Annual amount subject to interest (A)	$A = U$	\$251,300	\$249,600	\$264,678
Interest per year (i)	$i = A \times r$	\$17,591	\$17,472	\$18,527.46
Interest per part (I)	$I = i/D$	\$0.0117	\$0.0116	\$0.0124
<i>Overhead costs</i>				
Annual overhead costs (trans., rent, etc.) (v)		\$30,000	\$20,000	\$15,000
Overhead cost per part (O)	$O = v/D$	\$0.02	\$0.0133	\$0.01
Total production cost per part (excluding the cost of material)		\$4.7423	\$0.5211	\$0.2138

Acknowledgements

The author would like to express his appreciation to Dr. Ganesh Kothapalli of the School of Engineering, Edith Cowan University, Australia, for his contribution.

References

- [1] G. Boothroyd, W.A. Knight, *Fundamentals of Machining and Machine Tools*, Third Edition, Taylor & Francis, UK, 2005.
- [2] M. Wecka, D. Staimer, *Parallel Kinematic Machine Tools – Current State and Future Potentials*, *CIRP Annals: Manufacturing Technology* 51/2 (2002) 671-683.
- [3] J. Ko, S.J. Hu, T. Huang, *Reusability assessment for manufacturing systems*, *CIRP Annals* 54/1 (2005) 113-114.
- [4] M.P. Groover, *Fundamentals of Modern Manufacturing*, Fourth Edition, John Wiley and Sons Inc., 2010.
- [5] M.P. Groover, *Automation, production systems, and computer integrated manufacturing*, Prentice Hall, NJ, USA, 2008.
- [6] M. Tolouei-Rad, S. Zolfaghari, *Productivity improvement using Special-Purpose Modular machine tools*, *International Journal of Manufacturing Research* 4/2 (2009) 219-235.
- [7] J. Allen, D. Axinte, P. Roberts, R. Anderson, *A review of recent developments in the design of special-purpose machine tools with a view to identification of solutions for portable in situ machining systems*, *International Journal of Advanced Manufacturing Technology* 50 (2010) 843-857.
- [8] M. Tolouei-Rad, S.M. Tabatabaei, *Design and manufacture of modular special purpose machine tools*, *Proceedings of the 11th International Scientific Conference “Contemporary Achievements in Mechanics, Manufacturing and Materials Science” CAMS'2005, Giliwice – Zakopane, 2005 (CD-ROM)*.
- [9] I. Yoshimi, *Modular Design for Machine Tools*, McGraw-Hill Professional Publishing, Blacklick, OH, USA, 2008.
- [10] O. Suhner, *Automation Expert Catalogue*, Otto Suhner AG, Switzerland, 2001.
- [11] Suhner.com website.
- [12] D. Lutters, T.H.J. Vaneker, F.J.A.M. Van Houten, *What-if design: a synthesis method in the design process*, *CIRP Annals* 53/1 (2004) 113-114.
- [13] S. Myung, S. Han, *Knowledge-based parametric design of mechanical products based on configuration design method*, *Expert Systems with Applications* 21/2 (2001) 99-107.
- [14] L. Patil, S.S. Pande, *An intelligent feature process planning system for prismatic parts*, *International Journal of Production Research* 40/17 (2002) 4431-4447.